



Balanced Flue Gas Stoves

NEO



USER, INSTALLATION & SERVICING INSTRUCTIONS

For use in GB & IE (United Kingdom and Ireland)

This appliance has been tested and certified for other countries (see technical data). However to install appliance in other countries, modification of the appliance and its method of installation may be necessary in order to use the appliance safely and correctly. The manual for the local language must be obtained. Contact ACR for further information.

To be retained by the user for future reference.

Contents

Thankyou for purchasing an ACR Gas Stove.

To ensure you gain the most from your purchase, please read through this manual before operating for the first time.

Please keep this manual safe as it will be required to be completed by your Gas Safe engineer after each annual service.

Page 2. General Notes & User Instructions	Page 42. Technical Data
Page 3. User Instructions	Page 43. Dimensions
Page 4. Symax Handset User Instructions	Page 44. Servicing
Page 11. Manual User Instructions	Page 45. Annual Service Records
Page 12. Cleaning & Maintenance	Page 47. Warranty
Page 13. Installation Instructions	Page 48. Warranty Claim Form
Page 15. Clearance Requirements	
Page 16. Installation of Appliance	
Page 17. Burner Installation	
Page 19. Flue Connection	
Page 27. Positioning of Logs & Embers	
Page 32. Commissioning the Appliance	
Page 34. Briefing & Handover to the Customer	
Page 35. Gas Checklist, Dealer & Installer Information	
Page 36. Fault Finding Checklist	
Page 40. Spare Parts List.	
Page 41. Technical Information	

General Notes

IMPORTANT

Please read these instructions carefully before installation or use.

This appliance must be installed and serviced by a qualified person in accordance with local and national regulations.

The flue system must be installed and inspected by a qualified person in accordance with local and national regulations.

This product has been tested, and certified also for use on Biopropane Gas. Biopropane Gas can be used as a fuel, with no adjustment necessary if the product is installed as an LPG version.

This Manual covers the following Products:

NEO3FGAS – Neo 3F Gas Stove, 2 side windows 1 front door glass on 4 legs

NEO3PGAS – Neo 3P Gas Stove , 2 side windows 1 front door glass on a pedestal.

This ACR gas appliance is a high efficiency, Balanced Flue Live Fuel Effect appliance. It provides radiant and convected heat using the latest burner technology. As well as having a variable heat output, these fires also utilise a special control system that allows the appliance to function in thermostatic and timer modes. The stove can also be operated by a smart phone or tablet in conjunction with My Fire app & Module

▲ WARNING

Installation and service must be performed by a qualified installer, service agency, or the gas supplier. Installation shall conform with local codes, or in the absence of local codes, in accordance with the National Fuel Gas Code ANSI Z223.1/NFPA 54 or the IFGC or CSA B149.1. All piping and tubing must comply with local codes and ordinances.

Use only your hand to push in or turn the gas control knobs. Never use tools. If a knob will not push in or turn by hand, do not try to repair it. Call a qualified service technician. Force or attempted repair can result in a fire or explosion.

Do NOT use a product if you suspect it has been subjected to high temperatures, damaged, tampered with, or taken apart. Do NOT use a product if you suspect it has been under water or that liquid has seeped into the product. Any of these incidents can cause leakage or other damage that may affect proper operation and cause potentially dangerous combustion problems.

Do NOT store or use gasoline or other flammable vapours and liquids in the vicinity of this control or other appliances.

WHAT TO DO IF YOU SMELL GAS

- Do NOT operate any appliance.
- Do NOT touch any electrical switches; DO NOT use any phone in the building.
- Immediately evacuate the area and contact the gas supplier. Follow the gas supplier's instructions.
- If you cannot reach the gas supplier, call the fire department.

Read these instructions carefully and completely before installing or operating. Failure to follow them could result in a fire or explosion causing property damage, personal injury, or loss of life. Service and installation must be performed by a trained/experienced service technician.

User Instructions

Before installation, check that the local distribution conditions, nature of the gas and pressure, and adjustment of the appliance are compatible.

This appliance is intended for use on a gas installation with a governed meter.

This gas installation may only be installed by a registered professional competent person (Gas Safe installer in the UK). The installation must adhere to the requirements of the local and national Building Regulations and national standards. The installation manual must also be followed.

Emergency Gas Isolation

In the event of a gas leak or if gas is smelt, the appliance must be isolated. This is done by turning OFF the gas at the isolation tap. This isolation tap is located at the rear of the appliance.

We strongly recommend a carbon monoxide detector conforming to EN50291 is permanently fixed in the same room as the appliance.

WARNING

Do NOT use if leakage is detected. There is a danger of fire or explosion depending on conditions.

Operating the Appliance for the First Time

Before igniting the appliance, ensure that all packaging, safety stickers and any protective wrapping have been removed, and that the glass has been cleaned, including all fingerprints from the glass. If fingerprints are not removed, they will permanently mark the glass.

Ensure that the room is adequately ventilated the first time that the appliance is ignited; we would recommend opening windows if possible. Run the appliance at full setting for a few hours so that the paint gets an opportunity to fully cure. Take care not to touch the paint during this process as this will leave a mark.

During this period, it is possible for some fumes and vapours to be given off. We would recommend keeping children and pets out of the area at this time.

Symax Handset User Instructions

Technical Data

NOTICE

AMBIENT TEMPERATURE RANGE

CSA: 32 °F to 131 °F

CE: 0 °C to 55 °C

RADIO FREQUENCY

CSA: 918.0 MHz for U.S. (FCC), Canada (ISED),

New Zealand (RNZ) and Australia (ACMA) (handset, Receiver)

CE: 868.1 MHz for Europe (handset, Receiver)

To keep the Receiver free from debris, dirt, and humidity, do not remove the Receiver from the plastic bag until all construction is complete.

Wiring of valve and Receiver must be completed before starting ignition. Failure to do so could damage the electronics.

The handsets and Receivers are not interchangeable with previous electronics G6R and B6R-R8(9)U(T).

POWER SUPPLY

Handset: 2 x 1.5 V "AAA" (quality alkaline recommended)

Radio Frequency Receiver & Handset

A code is selected automatically for all Mertik Maxitrol electronics from among 65,000 codes available. The Receiver must be paired with a handset.

⚠ WARNING

To avoid damaging the electronics, do NOT use metal tools to remove the batteries from the handset / Receiver.

Without using a mains adapter, battery replacement is recommended at the beginning of each heating season. Old or dead batteries should be removed immediately. If left in the unit the batteries can overheat, leak, and/or explode.

Do NOT expose batteries (including during storage) to direct sunlight, excessive heat, fire, moisture, or severe impact. Each of these conditions can cause the batteries to overheat, leak, and/or explode.

Batteries must be kept within their recommended temperature limits (ambient battery temperature range: 32 °F to 131 °F / 0 °C to 55 °C).

New and old batteries and different brands of batteries should not be used together. Mixing of various batteries can cause the batteries to overheat, leak, and/or explode.

Handset One Button & Two Button Ignition

Change from one button (default setting) to two button ignition or vice versa by pressing and holding  button for 10 sec. immediately after installing batteries. The handsets and Receivers are not interchangeable with previous electronics G6R and B6R-R8(9)U(T). **ON** is displayed and **1** or **2** (One or Two Button Ignition) is flashing. When change is complete changes to **2** or vice versa.

Symax Handset User Instructions

Deactivate Functions

Install batteries. All icons are displayed and flashing.

While the icons are flashing, press the relevant function button and hold for 10 sec.

The function icon will flash until deactivation is complete. Deactivation is complete when the function icon and two horizontal bars are displayed.

NOTE: If a deactivated button is pressed, there is no function, and two horizontal bars are displayed.

NOTE: Deactivation remains in effect after change of batteries.

Activate Functions

Install batteries. All icons are displayed and flashing.

To activate a function, press the relevant button and hold for 10 sec.

The function icon will continue to flash until activation is complete. Activation is complete when the function icon is displayed.

The Following Functions can be Deactivated/Activated

- Child Proof
- Program Mode
- Thermostatic Mode (also deactivates Program Mode)
- Eco Mode
- Light/Dimmer Operation
- Circulating Fan Operation
- 2nd Burner Feature
- Countdown Timer

Symax Handset User Instructions

10 Button Handset Layout

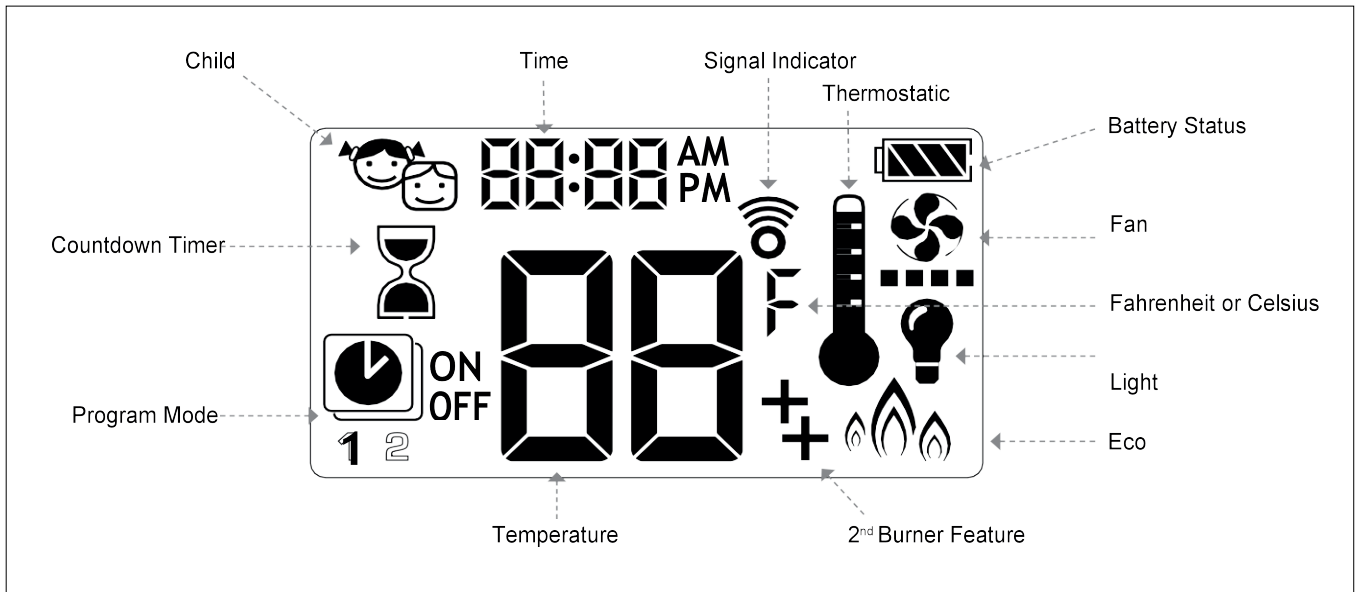

Setting The Fahrenheit or Celsius



To change between °C and °F, press and buttons simultaneously.

NOTE: Choosing °F results in a 12 hour clock. Choosing °C results in a 24 hour clock.

Setting The Time

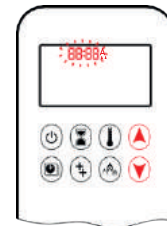

Press and buttons simultaneously. **Day** flashes.

Press or button to select a number to correspond with the day of the week (Monday = 1, Tuesday = 2, Wednesday = 3, Thursday = 4, Friday = 5, Saturday = 6, Sunday = 7)

Press and buttons simultaneously. **Hour** flashes.

To select hour press or button.

Press and buttons simultaneously. **Minutes** flash.

To select minutes press or button.

To confirm press and buttons simultaneously or wait.

Child Proof



ON:

To activate press and buttons simultaneously. is displayed and the Symax is rendered inoperable, except for the **OFF** function.

OFF:

To deactivate press and buttons simultaneously. disappears.

Flame Height Adjustment



To increase flame height, press and hold button

To decrease flame height or to set appliance to pilot flame, press and hold button.

Symax Handset User Instructions

NOTICE

BEFORE OPERATING

Make sure MANUAL knob on the GV60 valve is in the **ON**, full counter clockwise position.

Place the **ON/OFF** switch (if equipped) in the **I (ON)** position.

WARNING

When pilot ignition is confirmed, motor turns automatically to maximum flame height.

If the pilot does not stay lit after several tries, turn the main valve knob to **OFF**

To Turn ON Fire



Press button (One Button Ignition) or and button simultaneously (Two Button Ignition) until two short beeps (CE version) or continuous beeping (CSA version) and a blinking series of lines confirms the start sequence has begun; release button(s).

Main gas flows once pilot ignition is confirmed.

The Symax automatically goes into Manual Mode after main burner ignition.

To Turn OFF Fire



Press button to turn off.

NOTE: A new ignition is possible after the **OFF** icon stops flashing.

Designated Low/High Fire

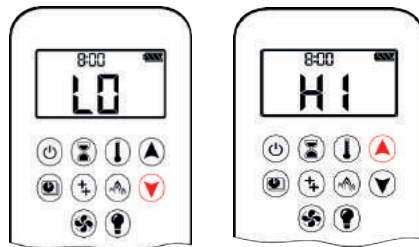

To go to low fire, double-click button. LO is displayed.

NOTE: Flame goes to high fire first before going to low fire.

To go to high fire, double-click button. HI is displayed.

Standby Mode (Pilot Flame)

Handset

Press and hold button to set appliance to pilot flame.

Countdown Timer



ON / SETTING:

Press and hold button until are displayed, and **hour** flashes.

To select hour press or button.

To confirm press button. **Minutes** flash.

To select minutes press or button.

To confirm press button or wait.

OFF:

Press button and Countdown Time disappear.

NOTE: At end of Countdown Time period, the fire shuts off. The Countdown Timer only works in Manual, Thermo-static, and Eco Modes. Maximum Countdown Time is 9 hours and 50 minutes.

Symax Handset User Instructions

Modes of Operation

Thermostatic Mode



ON: Press button until temperature gage is displayed, present temperature is displayed briefly, and then room temperature is displayed.

OFF: Press button.

Press Up or Down button to enter Manual Mode.

Press Program button to enter Program mode.

Press Eco button to enter Eco Mode.

Eco Mode



ON:

Press button to enter Eco Mode. is displayed.

OFF:

Press Eco button. Press Up or Down button to enter Manual Mode. Press button to enter Thermostatic Mode. Press button to enter Program Mode.

Program Mode



ON:

Press Program Button

Program, 1 or 2, ON or OFF is displayed.

OFF:

Press Program button.

Press or UP or DOWN button to enter Manual Mode.

Press button to enter Thermostatic Mode.

Press button to enter Eco Mode.

NOTE: The set temperature for Thermostatic Mode is the temperature for the **ON** time in Program Mode. Changing the Thermostatic Mode set temperature also changes the **ON** time temperature in Program Mode.

ON TIME (Thermostatic) TEMPERATURE: 70 °F / 21 °C

OFF TIME TEMPERATURE: " - " (pilot flame only)

Symax Handset User Instructions

Program Mode - continued





Default Setting

ON TIME (Thermostatic) TEMPERATURE: 70 °F / 21 °C

OFF TIME TEMPERATURE: “- -” (pilot flame only)

Press button and hold until  flashes and set temperature (setting in Thermostatic Mode) is displayed.

To continue press  button or wait is displayed, temperature flashes.

Select **OFF** temperature by pressing the  or  button.

To confirm press  button.

NOTE: The **ON** (Thermostatic) and **OFF** set temperatures are the same for each day.

Program Mode – Day Mode



ALL flashes. Press UP or DOWN button to choose between ALL, SA:SU, 1, 2, 3, 4, 5, 6, 7

Press the program button to confirm

ALL selected





ON TIME SETTING (PROGRAM 1):

Program, ON, 1 is displayed. ALL is displayed shortly & HOUR flashes.

To select hour press UP or DOWN button.

To confirm press Program Button. Program, 1, ON is displayed, ALL is displayed shortly, and **minutes** flash.

To select minutes press  or  button. To confirm press  button.





OFF TIME SETTING (PROGRAM 1):

Program, OFF, 1 is displayed. ALL is displayed shortly & HOUR flashes.

To select hour press UP or DOWN button.

To confirm press Program Button. Program, 1, OFF is displayed, ALL is displayed shortly, and **minutes** flash.

To select minutes press  or  button. To confirm press  button.

Symax Handset User Instructions

NOTE: Either continue to PROGRAM 2 and set ON and OFF times or stop programming at this point, and PROGRAM 2 remains deactivated.

NOTE: PROGRAM 1 and 2 use the same ON (Thermostatic) and OFF temperatures for ALL, SA:SU and Daily timer (1,2,3,4,5,6,7) Once a new ON (Thermostatic) and / or OFF temperature has been set, that temperature becomes the new default setting.

NOTE: If ALL, SA:SU or Daily Timer are programmed for PROGRAM 1 and PROGRAM 2. ON and OFF times these become the new default times. The batteries must be removed to clear the PROGRAM 1 and PROGRAM 2 ON and OFF times and temperatures.

SA:SU or Daily Timer (1,2,3,4,5,6,7) selected

Set ON time and OFF time using same procedure as ALL selected (above)

SA:SU set ON time and OFF time for both Saturday and Sunday

Daily Timer: Unique ON and OFF times may be set for a single day of the week, for multiple day of the week, or for everyday of the week.

Wait to finish setting.

2nd Burner Feature



The latching solenoid valve will open automatically after ignition or after switching the system **OFF**, so that the maximum flow of gas is supplied to both burners assisting with the ignition process. After pressing the button for the 2nd Burner the motor will turn 7 seconds in the **ON** direction until the max. position is reached.

ON:

To switch a burner **ON**, press the  button displayed.

OFF:

To switch the burner **OFF**, press the button disappears.

NOTE: The latching solenoid valve cannot operate manually. If the Receiver battery runs down it will remain in the last operating position.

Light/Dimmer Operation



ON: Press  button (is displayed). Light is **ON** at present level.

OFF: Press  button (button disappears).

SETTING:

Press button and hold until flashes. Adjust light between 20-100% using UP and DOWN.

To confirm setting either press button or wait until button is displayed.

NOTE: The light works independently of the pilot flame. If you want the light ON but no flames press button

Manual User Instructions

Knob Settings

KNOB	POSITION	FUNCTION
Main valve knob	OFF	Permits main gas flow through valve.
Main valve knob	ON	Permits main gas flow through valve if pilot is lit and thermocouple is generating sufficient power.
Manual knob	MAN	Allows pilot to be manually ignited and prevents main gas flow.
Manual knob	ON	Allows automatic ignition.

Manual Turn Off

In the event that the appliance needs to be turned OFF manually, for instance, if the remote control is lost or the batteries become totally flat, the control valve must be accessed and the switch flipped to OFF (marked "0").

The picture below shows the control valve.

The control valve is located behind the control hatch in the Base of the appliance.

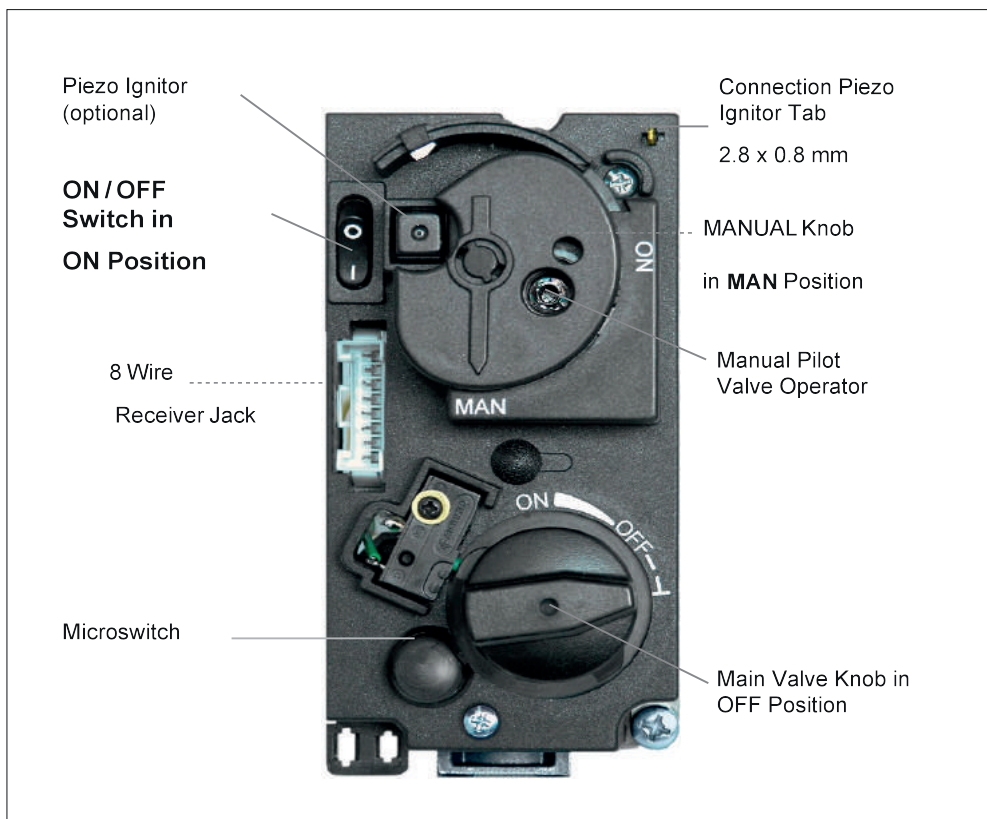

Cleaning & Maintenance

Never attempt any cleaning or maintenance of the appliance unless the appliance is cold

This appliance should be inspected and serviced once a year by a qualified, competent and registered person.

The inspection and maintenance must at least ensure that the appliance is working correctly and safely.

It is advisable to clean the exterior of the appliance of any dust and debris regularly during the heating season and especially if the appliance has not been used for some time.

This can be done with a soft brush and a vacuum cleaner or a damp cloth and if required a non-abrasive cleaning agent.

Do not use corrosive or abrasive substances to clean the exterior of the appliance as this may damage the painted finish of the stove.

This appliance uses 4 x AA batteries for the ignition and control of the stove.

To access to these batteries, reach under the appliance and remove the control unit located to the rear right hand side of the appliance, remove the top cover and replace the existing batteries.

Never use a metal tool to remove the batteries as this may damage the control unit.

Once the batteries have been replaced always refit the contro

Installation Instructions

⚠ WARNING

Protective clothing should be worn when installing the appliance.

Care should be taken when lifting this appliance due to its weight.

We strongly recommend a carbon monoxide detector (conforming to EN50291) is permanently fixed in the same room as the appliance.

Ensure that the Flue Terminal is not in any way obstructed and is clear of vegetation, i.e. trees, shrubs etc. and that no objects are leant against the terminal or guard.

Always clean the Window Panel before the fire is initially ignited. Any finger prints must be removed, as these will be burnt into the glass and will be un-removable.

Do not operate this appliance if the glass panel has been broken (or cracked), removed or is open.

The appliance is designed to fit numerous installation situations as listed in these installation instructions. However only flue approved by ACR for this appliance may be used. 3 standard kits are available through ACR. Additional parts can be purchased from Poujoulat but must be approved by ACR.

This appliance is a balanced flue product and is room sealed and as such requires no additional ventilation for operation. However an adequate supply of fresh air to maintain temperatures and a comfortable environment is recommended.

This appliance is designed as a heating appliance, and as such will get very hot in operation; all surfaces (except the controls and access door) are considered to be working surfaces and as such should not be touched. The front windows and surrounds are not considered to be fully secure guards against accidental contact. It is recommended that an approved fire screen be used if children, the elderly or persons with limited mobility are to be present in the same area.

Do not place curtains, laundry, furniture etc. within a safe distance of 300mm of this appliance.

Do not attempt to burn rubbish on this appliance.

If this appliance is extinguished, on purpose or other, no attempt to relight should be made within 3 minutes.

Unpacking

Remove the appliance from its packaging and check for any damage or missing items before commencing the installation.

Packing List

- **Appliance**
- **Log Set**
- **Remote control handset**
- **Bag of embers**
- **Glow fibre pack**
- **Burner**

Before commencing installation, confirm that the details on the appliance data plate correspond to the local distribution conditions, gas type and pressure to which the appliance is to be installed. Check you are in receipt of the correct gas type burner.

Ensure the gas supply and supply pipe is capable of delivering the required volume and pressure of gas and is in accordance with the rules in force.

Installation Instructions

Gas Connection

This appliance has a gas inlet connection of \varnothing 8mm.

Ventilation

This appliance is a Balanced Flue room sealed appliance, and as such needs no additional ventilation. However, an adequate supply of fresh air to maintain temperatures and a comfortable environment is recommended.

This appliance may be installed in a completely sealed or mechanically ventilated house.

Do not install the appliance in a bathroom or a room that contains a bath or shower.

Do not cover the appliance and or do not wrap it in an insulation blanket or any other material.

Do not make any changes to the appliance.

The gas connection must be in accordance with local and national regulations.

This appliance is intended for use on a gas installation with a governed meter.

Appliance Fireplace Installation

Determine the position required for the appliance.

Create a gas connection for the appliance in approximately the correct location for the gas controls.

The gas controls are connected to the Burner of the appliance.

For clearance details see below.

The clearance distance of the Flue from combustibles must not be less than 75mm. This dimension can be reduced to 25mm as the distance from the underside and the sides of horizontal flue runs.

Hearth

A hearth conforming to national regulations should be provided for the stove extending to at least the front of the supporting legs, and to at least each side of the stove. ACR recommend a hearth footprint 50mm more on all 4 sides than the footprint of the appliance. The hearth should have a minimum thickness of 12mm.

Clearance Requirements

Corner Installation – Distance to combustibles

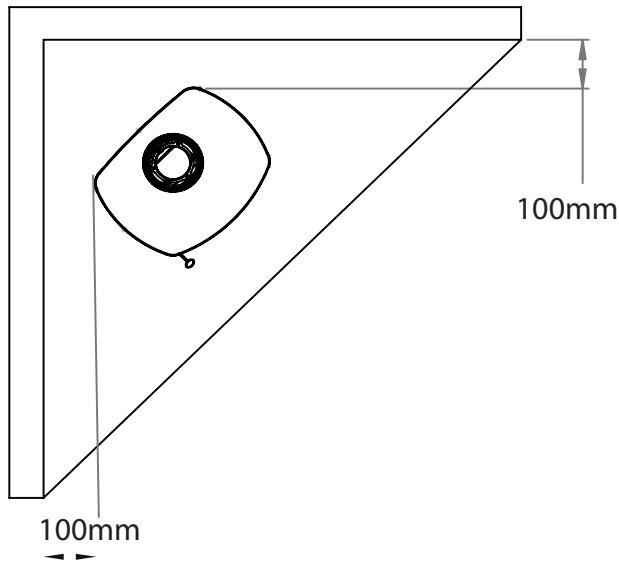

Side & Rear – Distance to combustibles

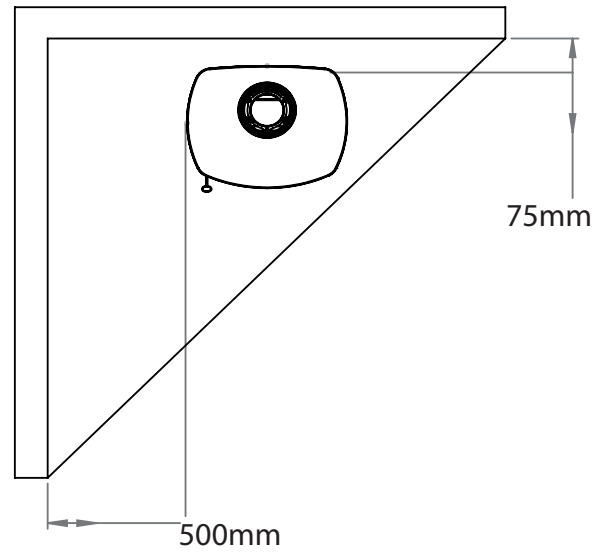

Above – Distance to combustibles

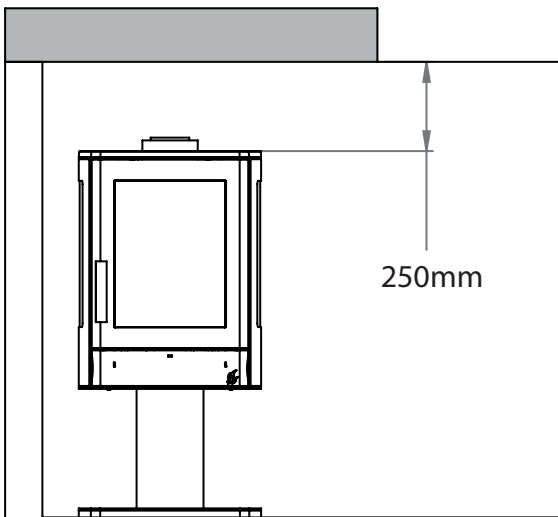

All clearances stated provide the minimum distance to combustible material. If the appliance is to be installed in a non-combustible opening, these clearances can be reduced but the clearance for the rear must always be 50mm minimum. You **must** ensure that if reducing the clearances to the sides or above, provision is made for servicing & maintenance purposes and adequate air flow around the appliance can be maintained. However, we would recommend you adhere to the clearances to combustibles wherever possible.

Installation of the appliance

The appliance is supplied in separate boxes, please refer to the packing list above.

The installer is required to install the burner, optional rear panel, optional LED kit and log set to the appliance.

Flue configuration

The appliance is pre-set with a vertical flue configuration, if this is the desired flue route then no further action needs to be taken.

The appliance is able to be installed with a rear flue option when used in conjunction with the ACR snorkel kit, to prepare the appliance for this application the flue collar assembly will need to be removed from the top of the appliance and swapped to the rear of the appliance.

1. Remove free floating top plate, remove air intake collar and gasket, and remove inner flue outlet collar and gasket.

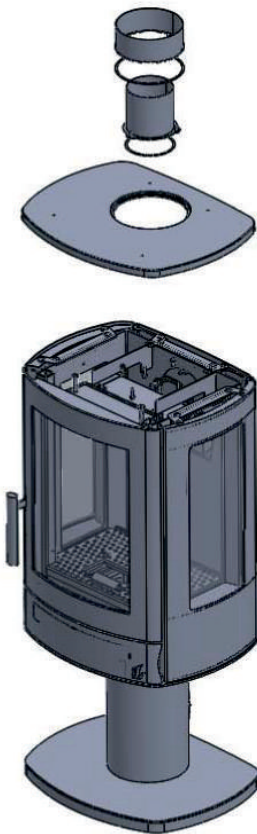

2. Swap the blanking plates, flue collars and gaskets and retighten fixing bolts. Place the cosmetic blanking plate onto the top of the free - floating top plate.

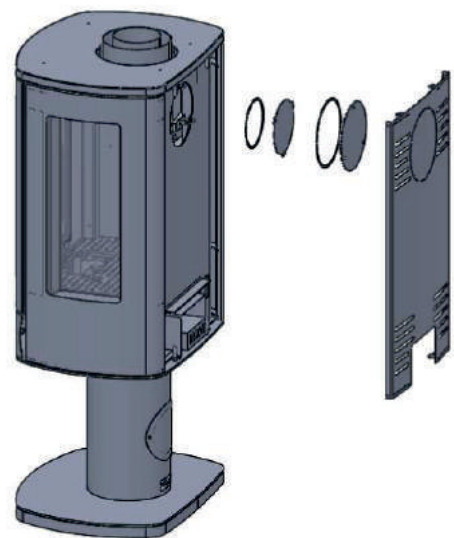

Burner installation

Before connecting the burner please ensure that the gas supply pipework is in the correct position for connection to the unit, please ensure that the gas supply pipework is purged and free from debris.

1. To access the combustion chamber please loosen the retaining bolt located in the handle below the roller cam locking mechanism.

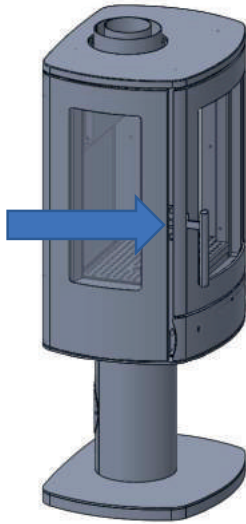

2. Lift out the perforated grate from the combustion chamber.

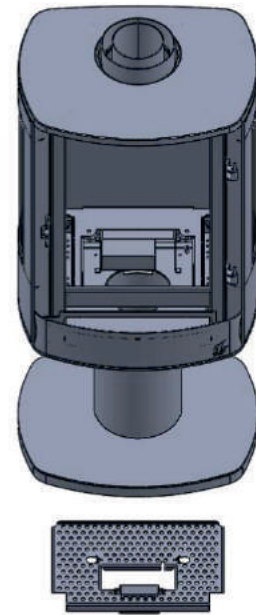

3. Unpack the complete burner and insert the burner into the combustion chamber. Secure the burner to the base of the appliance using the 4 bolts provided ensuring that the seal is fully compressed on all sides. Please pay careful attention to make sure that the attached control box and associated wiring are not trapped between the bottom of the burner and the combustion chamber. Ensure that the flexible gas supply pipe is not damaged by the rear of the plate located inside the combustion chamber.

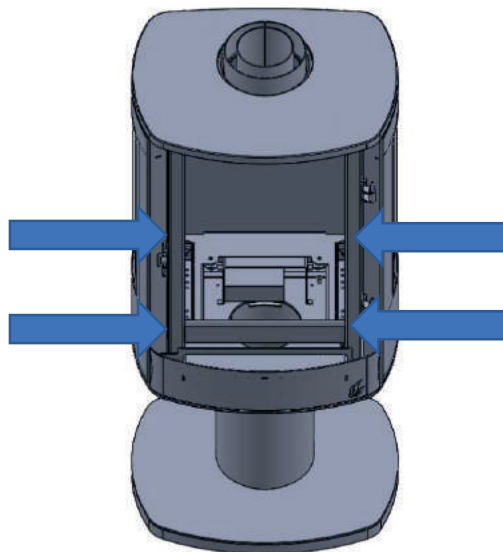

4. Place the control box into the holder located on the underside back left of the appliance ensuring that the wiring is not trapped in any way.

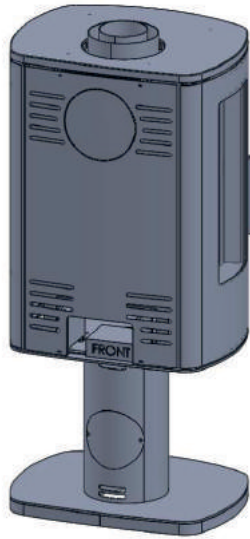

5. Replace the perforated grate.

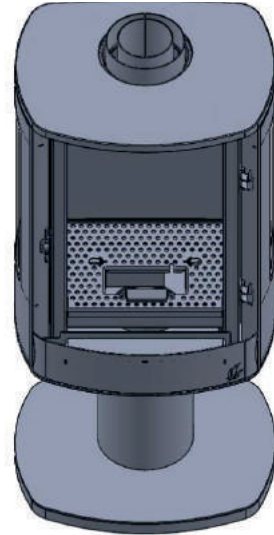

6. Place the elevated burner ports onto the left and right gas outlets as shown. The left-hand elevated port should sit in the 6th groove from the front. The right-hand elevated port should sit in the 3rd groove from the front. Make sure that both ports are securely located on the outlet ports.

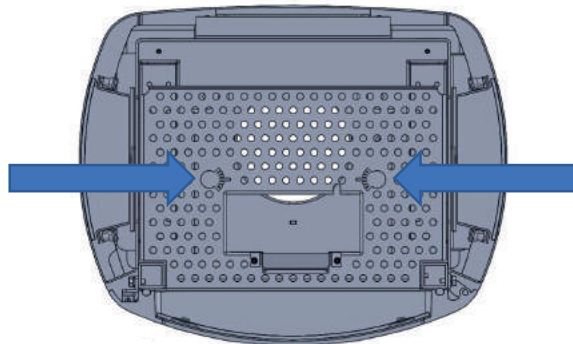

7. The appliance is now ready to be connected to the gas supply pipework and the flue connection can be made.

Flue Connection

General Notes

This appliance may be installed with a roof terminal or a wall terminal.

This appliance may only be used with Balanced Flue (otherwise known as Concentric Flue) parts as specified by ACR. The ACR specified flue parts have been approved with the appliance. If the appliance is installed on non-ACR approved parts, ACR cannot guarantee or accept any responsibility for the proper and safe working of the appliance. Please check the latest approved flue suppliers with ACR prior to purchasing,

The flue system must be constructed from the appliance upwards, with all joints being fully locked and sealed using the ACR specified parts.

If installing the flue renovation kit, the existing flue must be swept & checked for soundness prior to installation.

Timber Frame Construction

Whilst it is possible to install room-sealed appliances in timber frame properties, great care needs to be taken to ensure that the flue assembly does not interfere with the weather proofing qualities of any outer wall which it may penetrate. Before attempting this work, further details need to be referenced, (e.g. "Gas Installations in Timber Frame Buildings" from the GAS SAFE installer publications in the UK).

Car Port or Building Extension

Where a flue terminal is sited within a car port or building extension, it should have at least two completely open and unobstructed sides. The distance between the lowest part of the roof and the top of the terminal should be at least 600mm.

Note: A covered passageway should not be treated as a car port. Flues should not be sited in a covered passageway between properties.

Basements, Lightwells and Retaining Walls

Flue terminals should not be sited within the confines of a basement area, lightwell or external space formed by a retaining wall, unless steps are taken to ensure the products of combustion can disperse safely at all times. It may be possible to install this Balanced Flue system in such a location provided that it is not sited lower than 1m from the top level of that area to allow combustion products to disperse safely.

Flue terminals should be sited to ensure total clearance of the combustion products in accordance with the manual.

When the products of combustion are discharged, they should not cause a nuisance to adjoining or adjacent properties and they should be positioned so that damage cannot occur to other parts of the building. If the outer wall surface is constructed of combustible material, a non-combustible plate should be fitted behind the terminal projecting 25mm beyond the external edges of the terminal

Terminal Guards

The flue outlet should be protected with a terminal guard conforming to BS5440-1 if persons could come into contact with it, or if it could be damaged or if it is in a vulnerable position such as where the flue discharge is within easy reach from the ground (less than 2m) balcony, veranda or an opening window.

The flue outlet can be either taken from the standard top exit or converted rear exit of the appliance.

Terminal Locations

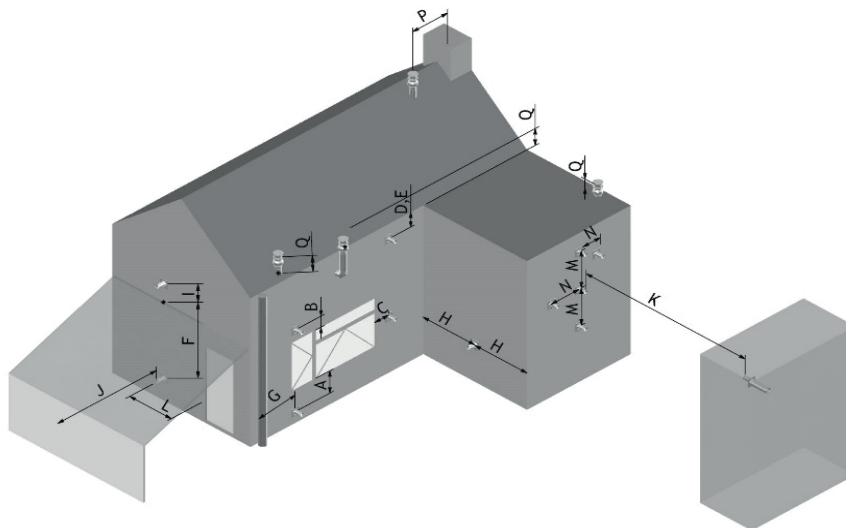

Dimension	Terminal Position	Distance (mm)
A*	Directly below an opening, air brick, opening window etc.	600
B	Above an opening, air brick, opening window etc.	300
C	Adjacent to an opening, air brick, opening window etc.	400
D	Below gutters, soil pipes or drain pipes	300
E	Below eaves	300
F	Below balconies of car port roof	600
G	From a vertical drain pipe or soil pipe	300
H	From an internal or external corner	600
I	Above ground roof or balcony level	300
J	From a surface facing the terminal	600
K	From a terminal facing the terminal	600
L	From an opening in the car port (e.g. door, window into the dwelling)	1200
M	Vertically from a terminal on the same wall	1500
N	Horizontally from a terminal on the same wall	300
P	From a vertical structure on the roof	600
Q	Above intersection with roof	150

* In addition, the terminal should not be nearer than 300mm to an opening in the building fabric formed for the purpose of accommodating a built-in element such as a window frame.

Wall Vent Terminations

Horizontal Wall Vent Termination

Flue sizing:

Neo: \varnothing 100/150 Connector on appliance.

\varnothing 100/150 Maybe used throughout.

Maximum pipe extension, for outside wall (H)

= 1 X Vertical Pipe Rise (V). For \varnothing 100/150 flue.

Maximum Permissible Run (H) =15m.

Flue Restrictors to be fitted, \varnothing 100/150:

Neo	
Vertical Rise < 1m	No Restrictor
Vertical Rise 1-2m	35mm Restrictor
Vertical Rise 2-4m	40mm Restrictor
Vertical Rise 4-6m	50mm Restrictor
Vertical Rise 6-9m	35mm Restrictor
Vertical Rise >9m	No Restrictor

Vertical Roof Vent Termination

Flue sizing:

Neo: \varnothing 100/150 Connector on Appliance.

\varnothing 100/150 Maybe used throughout.

Flue Terminal: \varnothing 100/150

Part No. USDVC 100

Minimum Vertical Flue Height: Neo - 0.5m

Flue Restrictors to be fitted, \varnothing 100/150:

Neo	
Vertical Rise < 1m	No Restrictor
Vertical Rise 1-2m	35mm Restrictor
Vertical Rise 2-4m	40mm Restrictor
Vertical Rise 4-6m	50mm Restrictor
Vertical Rise 6-9m	35mm Restrictor
Vertical Rise >9m	No Restrictor

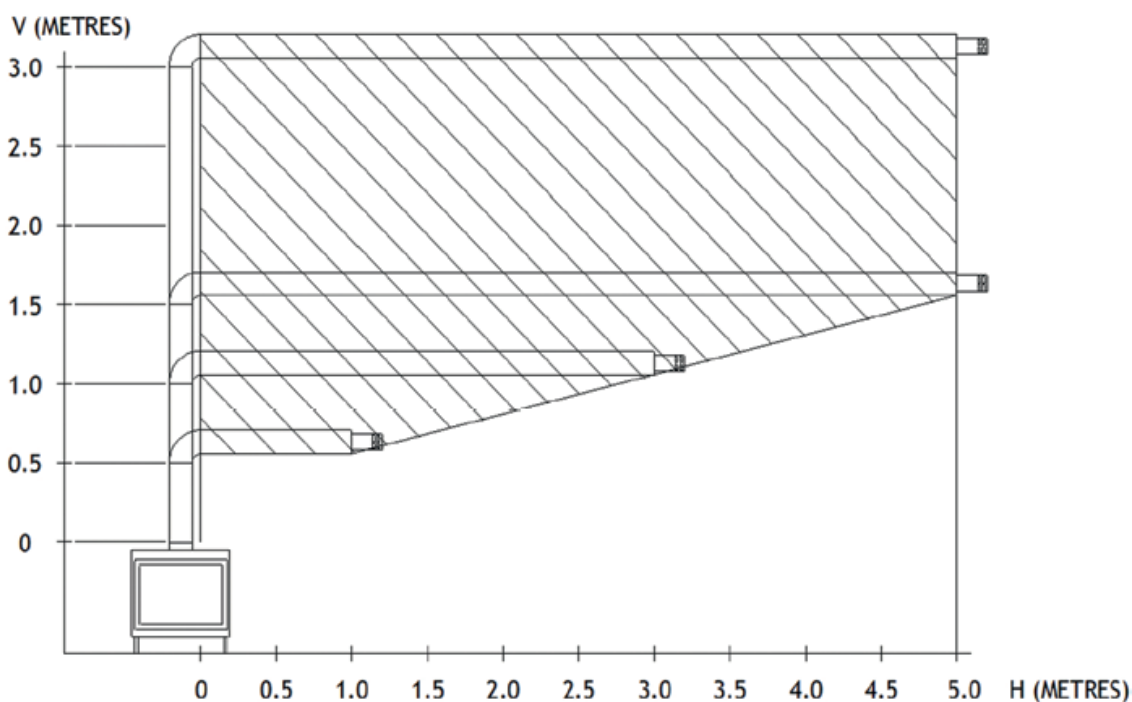

Rear Flue Configuration

IMPORTANT

When using the rear flue option from the Wychwood Gas Stove, it is imperative that the below configuration is adhered to at all times.

The Snorkel Terminal (GFK2 ACR REAR SNORKEL KIT) **MUST** always be installed inline with manufacturers instructions and a maximum horizontal length of 500mm before affixing the snorkel terminal.

Under no circumstances should any other rear flue configuration be used as this may cause a danger to persons & property.

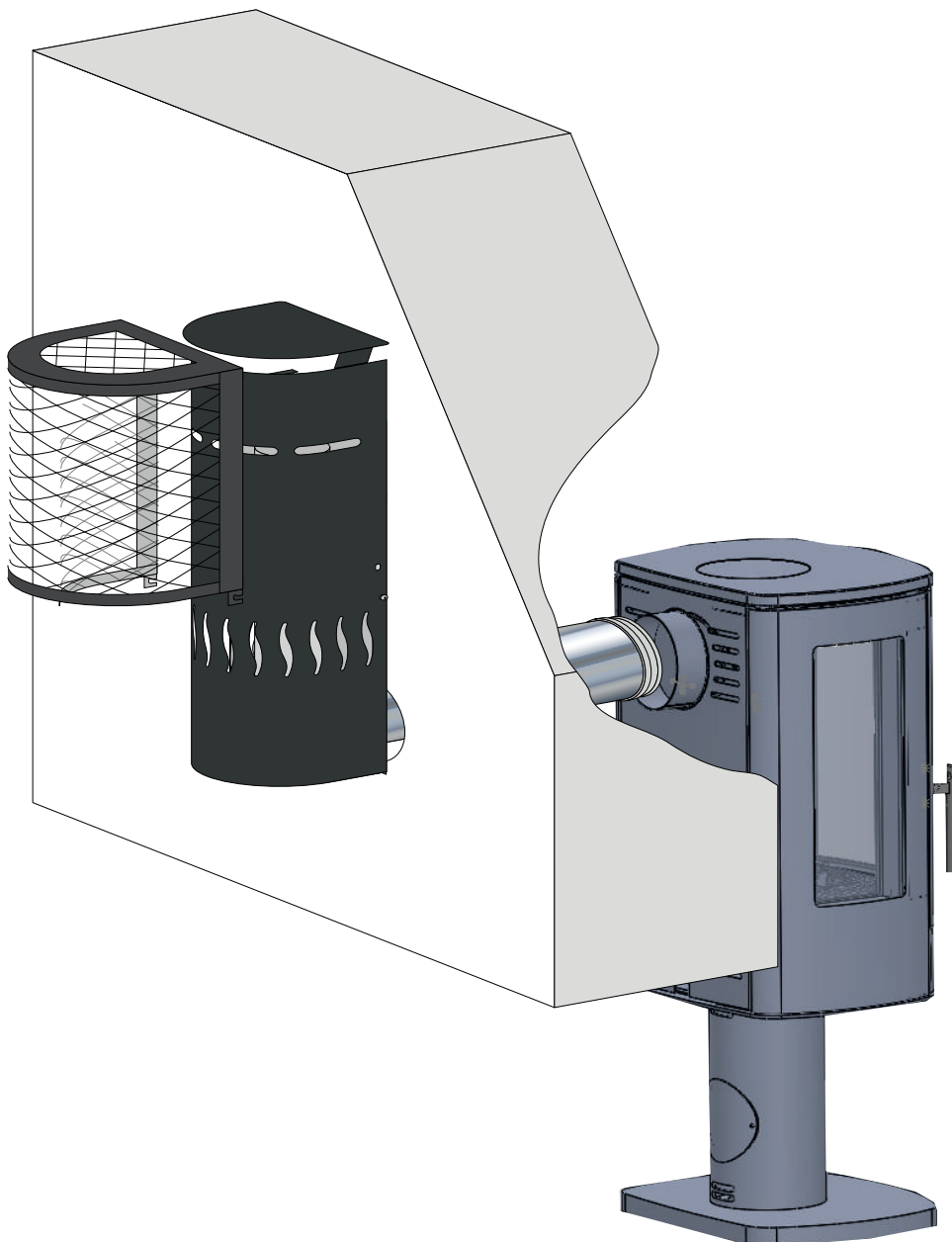

Examples of possible alternative flueing arrangements*

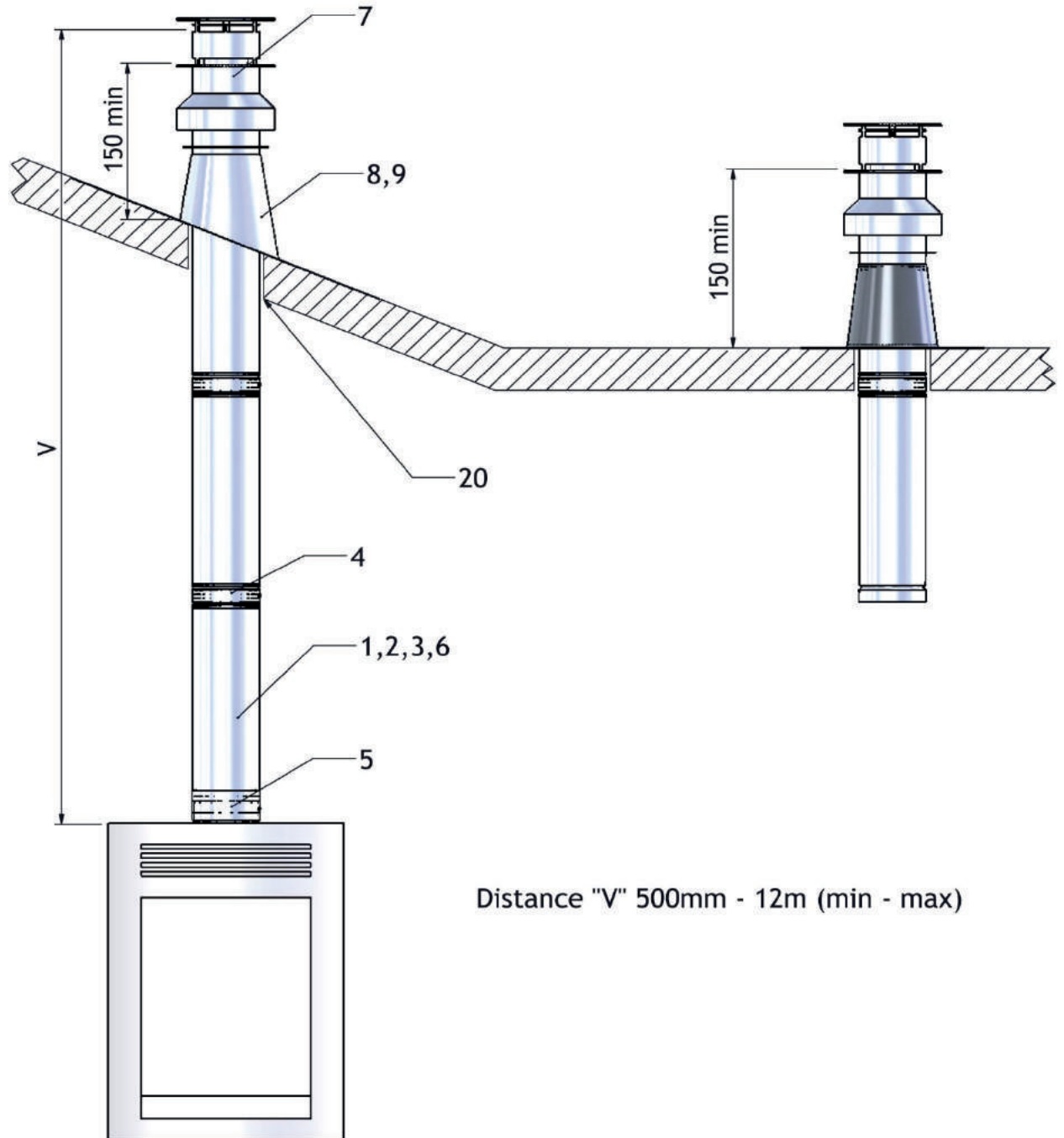

Distance "V" 500mm - 12m (min - max)

*Contact your local dealer for more information

Examples of possible alternative flueing arrangements*

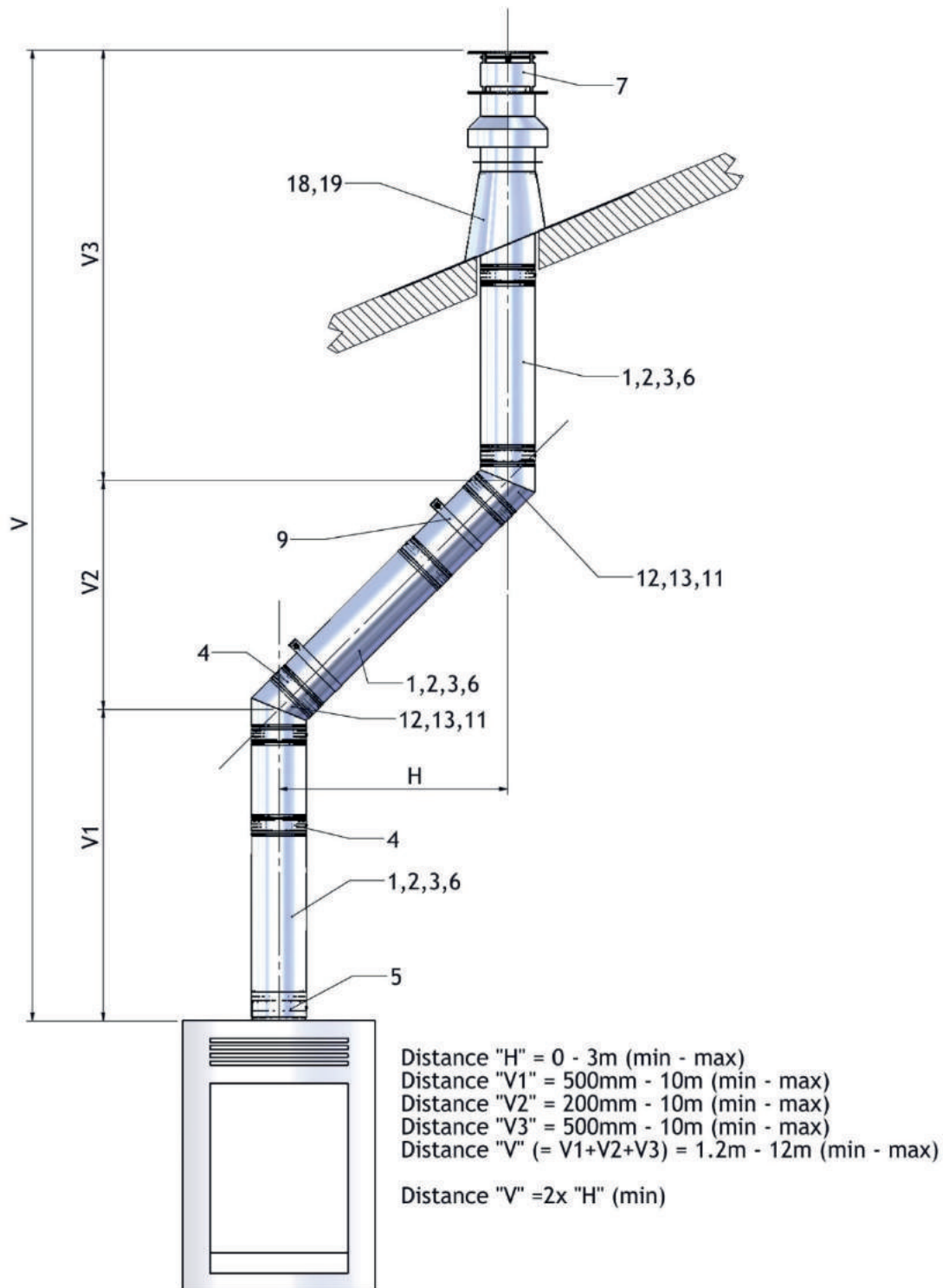

*Contact your local dealer for more information

Examples of possible alternative flueing arrangements*

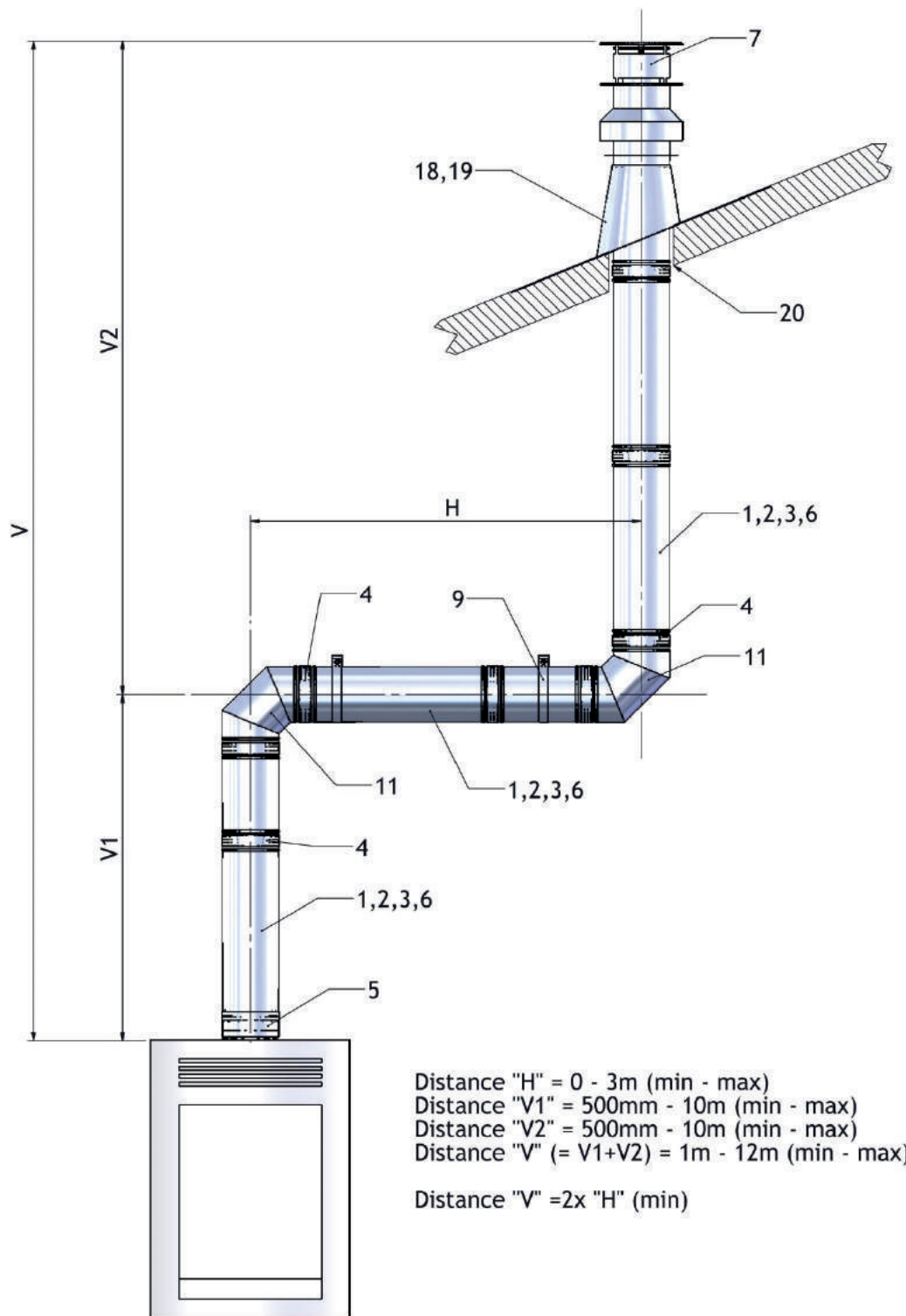

*Contact your local dealer for more information

Examples of possible alternative flueing arrangements**

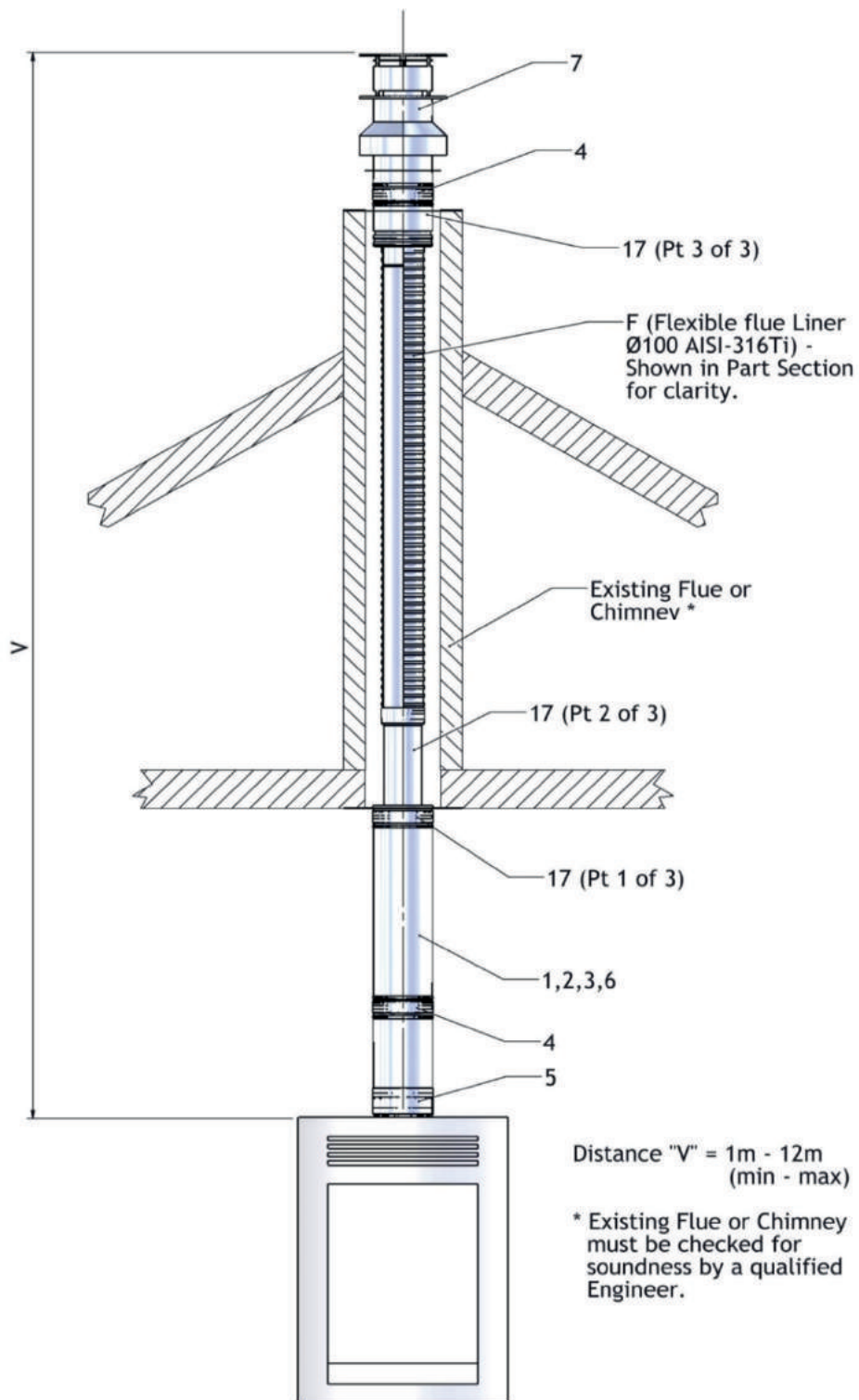

**Contact your local dealer for more information

Log Layout



This kit will contain:

Crystals

*Crystals are only available with LED light options

Bark Effect

Fireglow Fibres

8 Realistic Hard Ceramic Logs

2 Elevated Burner Ports

Log Layout

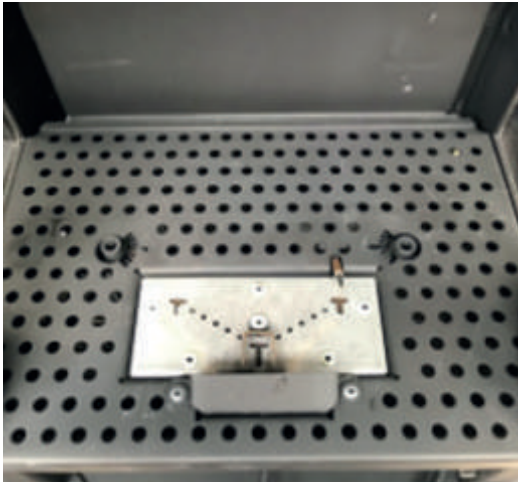

Step 1 - Place the elevated burner ports into the lower burner ports. Press firmly down to secure. This is where the gas will be released from & enter into the stove chamber.

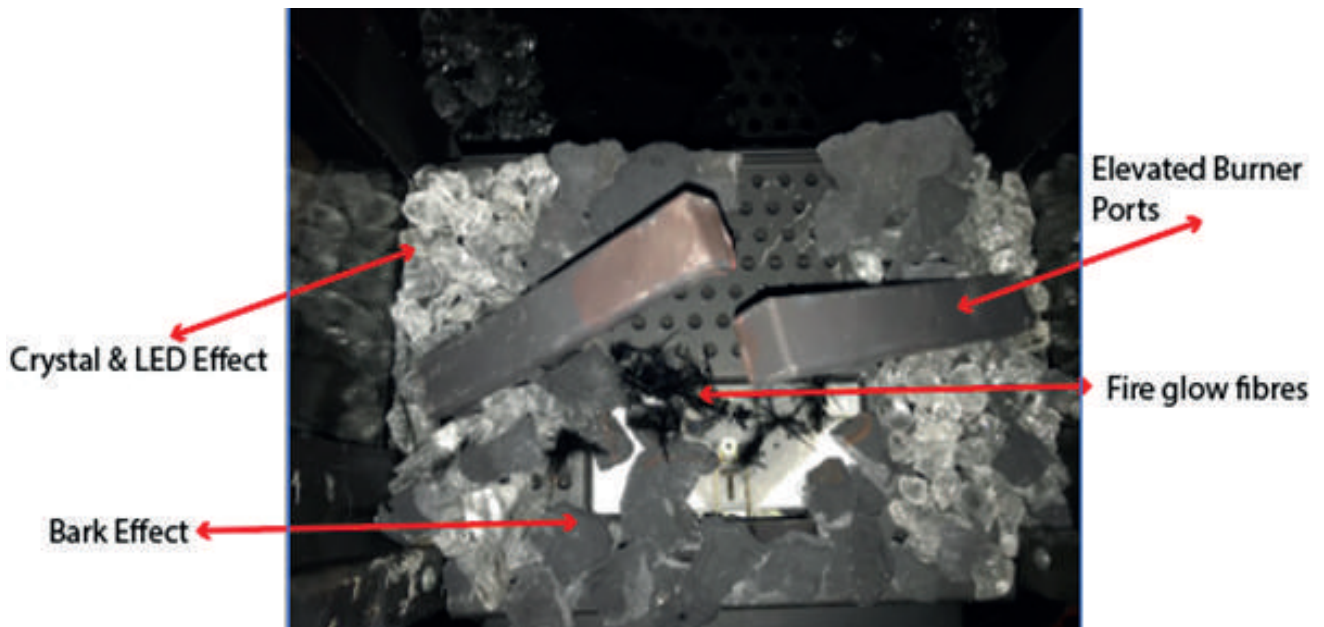

Step 2 - Once the Elevated Burner Ports are in place. If you have asked for the LED option in your gas stove, place the crystals accordingly into the base of the appliance.

Step 3 - Scatter the bark effect towards the front and the rear of the appliance

Log Layout – Step by Step

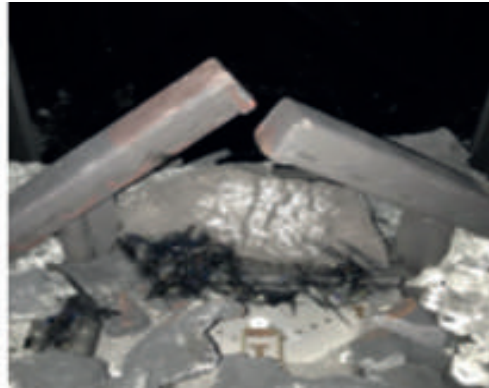

Step 4 – Place Log 1 into the chamber. This needs to be situated under the Elevated Burner Ports in a central position.

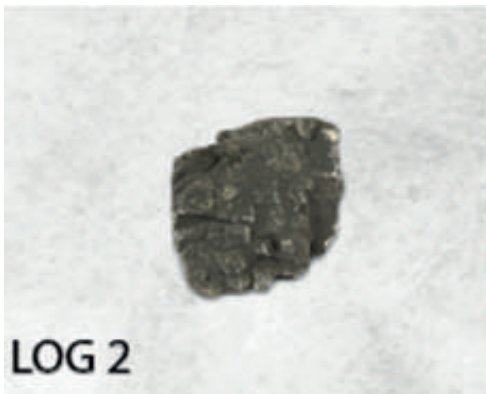

Step 5 – Place Log 2 into the chamber. This needs to be placed to the back of the stove, to the rear of Log 1

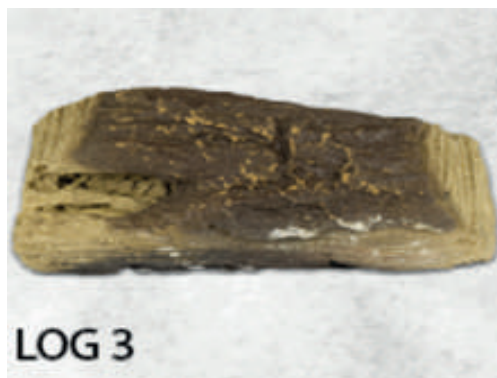

Step 6 – Place Log 3 on top of the Left Elevated Burner Port. The bark side of the log should be facing upwards.

Log Layout – Step by Step



Step 7 – Place Log 4 on top of the Right Elevated Burner Port. The scorched looking side of the bark facing the front.



Step 8 – Place Log 5 below the 2 Burner Ports that are now hidden by logs 3 & 4

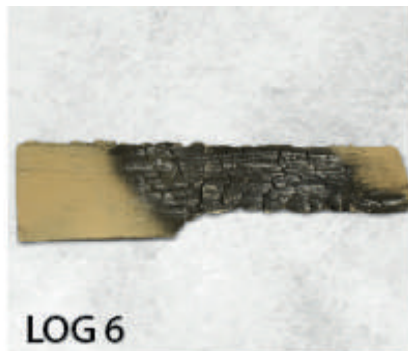

Step 9 – Place Log 6 in between log 3 and 4 with the scorched bark front facing.

Log Layout – Step by Step



Step 10 – Place Log 7 on top of log 5. The scorched end of the log touching the middle of log 5.



Step 11 – Place Log 8 on top of log 5 & in front of log 7. The scorched end of the log should be facing towards log 4.

Commissioning the Appliance

Pilot Ignition Check

1. Ignite the pilot light as described in the User Instructions
2. Check that the pilot flame stays alight
3. Extinguish the pilot light
4. Ensure the glass is clean & fingerprints are removed prior to lighting as these could mark the glass permanently.

Main Burner Check

1. Ignite the pilot light as described in the User Instructions
2. Turn on the main burner as described in the User Instructions
3. Check that the pilot smoothly cross-lights to the main burner and that the main burner and pilot stay alight
4. Check the operation as described in the User Instructions
5. Extinguish the appliance fully

Pressure Check

The appliance is present to give the correct heat inputs as listed in the technical details. No further adjustment is necessary. Always check the inlet pressure and burner pressure.

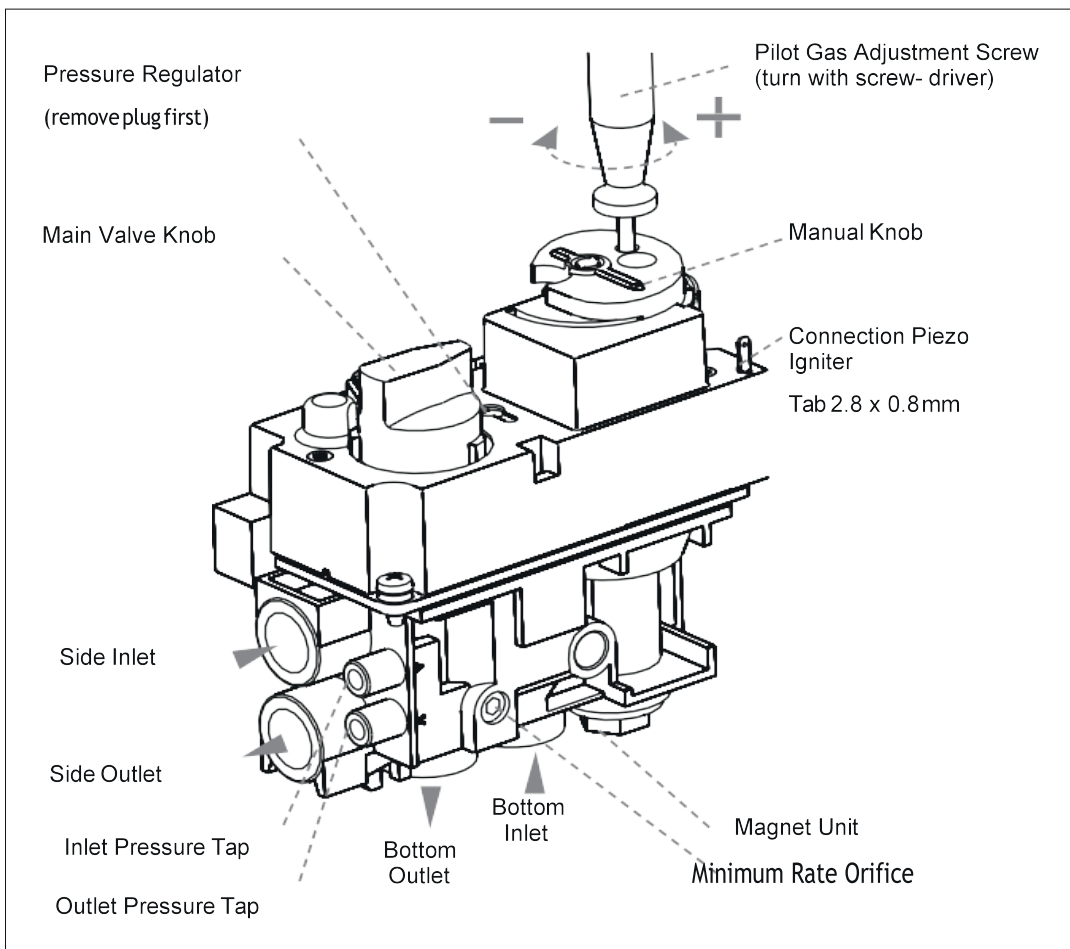

Pressure Check Instructions:

1. Turn off the gas valve on the appliance
2. Release the screw on the Inlet Pressure test point on the gas valve and connect a manometer
3. Check that the measured pressure is as the prescribed supply pressure
4. Perform the test when the appliance is burning on full (Inc. "effect" burners) and with only the pilot alight
5. If the pressure is low, check the gas supply pipes are to a correct sizing
6. If the pressure is too high (more than 5 mbar over) the appliance may be installed, but the gas supply company should be contacted before commissioning continues.
7. Release the screw on the Burner Pressure test point on the gas valve and connect a manometer
8. Check that the measured pressure is as detailed in the Technical details
9. The measured value should be within +/- 10% of the described value. If this is not the case, please contact the supplier.

Note: After checking the pressures and removing the manometers, the screws in the Pressure Test points must be closed, and the system must be checked for gas-tightness.

Flame stability

IMPORTANT NOTE - The appliance should always be observed when lighting. On starting the appliance, the ignition will light the pilot, once established the main valve opens to 'High rate' to allow gas through to the main burner. All of the main burner should light within 6 seconds lighting the whole burner area.

If this does not happen then the appliance should be turned off allowing 3 minutes before attempting to relight.

Check the stability of the flame by turning to low rate then back to high rate then to low rate doing this around three times whilst observing the stability of the main burner and pilot flame, there should be no problems lighting the main burner.

Briefing & Handover to the Customer

Instruct the customer on the full operation of the appliance.

Warn the customer that the fire unit may give off a temporary odour; this is normal running in of the unit, and will disappear after a short period of use.

Inform the user that the appliance glass is only to be opened when servicing, and not to disturb the fibre logs as this may disturb the combustion.

Inform the customer that it is recommended that a full service on the appliance and flue checks be carried out annually by competent person/s.

Caution - Make the user aware of the location of the isolation valve and tell the user to close the isolation immediately in case of malfunction / bad performance and to contact the installer in order to prevent dangerous situations.

Instruct the user that the pilot light and flame sensing device fitted to this appliance is also an atmospheric sensing device, designed to shut off the appliance if the evacuation of products of combustion is disturbed. If the appliance repeatedly shuts off after being restarted (as detailed in the 'Lighting instructions' section), a GAS SAFE registered engineer should be contacted to examine the appliance and installation.

Inform the user to always observe the appliance when lighting, once the pilot is lit the main valve then opens to 'High rate' allowing gas through to the main burner. The main burner should then light within 6 seconds **if this does not happen then the appliance should be turned off allowing 5 minutes before attempting to relight.**

Warn the user of the following points:

- That all parts of the appliance will become hot while the appliance is running, so it is recommended that a guard conforming to BS8423: 2002 be used for the protection of young children, aged or infirm persons.
- Not to stand too close to the appliance for prolonged periods of time; loose clothing is particularly at risk of burning, and that rubbish cannot be burned in the unit.
- Against placing combustible material directly in front of the appliance. Floor coverings such as carpets, are considered to be acceptable.

Ensure the installer details are filled in.

Gas Checklist

Gas Checklist	Pass	Fail
Gas Tightness Test		
Standing Pressure		
Working Pressure		
Burner Pressure		
Heat Input		
Door Locked & Secured		

Dealer & Installer Information

Dealer:
Contact No:
Date of Purchase:
Model No:
Stove Serial No:
Burner Serial No:
Gas Type:



Installation Company:
Gas Safe Registered Engineer:
Contact No:
Gas Safe Register No:
Date of Installation:

Fault Finding Checklist



ISSUE	POSSIBLE CAUSE	SOLVE
Will not operate with handset	1. Transmitter batteries low	Replace Transmitter batteries. Quality alkaline recommended.
	2. Receiver batteries low	Replace Receiver batteries with 1.5 V"AA" quality alkaline batteries.
	3.Optional Mains Adapter not operating properly	Check Mains Adapter
	4.Check coding of Transmitter and Receiver (Initial Sync.)	Learn new code (reset). See label on receiver.
	5.Transmitter distance limited	1. Straighten the Antenna 2. Replace Receiver, See wiring diagrams, pg. 8-12, in the operating/installation instructions for the GV60

ISSUE	POSSIBLE CAUSE	SOLVE
Frequent beeps for 3 seconds while motor turns.	1.Batteries (Receiver) are low	Replace batteries (Quality Alkaline recommended). ⚠ WARNING Do not use metal tools to remove batteries. Doing so will render the Receiver inoperable.
Pilot Flame lights but there is no main gas flow	1.Manuals override knob (if equipped) is in MAN position.	Turn Manual override knob to ON position.
	2.Valve turned down to pilot flow	Turn flame to high fire by pressing up button on remote handset,
	3.Valve	Replace Valve. Do not overtighten the Thermocouple Interrupter.
Latching Solenoid does not work.	1.Loose connection	Check Connection is tight and pins are straight
	2.Latching Solenoid	Replace Latching Solenoid
	3.Receiver	Replace Receiver and reprogram code.
	4.Handset	Check that the Handset shows the AUX-symbol if you press SET + UP

Fault Finding Checklist

ISSUE	POSSIBLE CAUSE	SOLVE
No Ignition: one 5 second continuous tone:	1.ON/OFF Switch is in (O) OFF position.	Push Switch to (-) ON position (see figure 7).  <p style="font-size: small;">Figure 7 ON/OFF Switch 8 Wire Connector</p>
	2. Loose wire	Secure wire
	3.Receiver	Replace Receiver and reprogram code (see OBSERVED PROBLEM C, REMEDY to POSSIBLE CAUSE 2).
	4.Bent pins on 8 Wire Connector (see figures 7 and 9)	Straighten pins on 8 Wire Connector.
	5.Valve	Replace Valve. Do not overtighten the Thermocouple Interrupter.
Ignition stops after the first spark	1.Loose ground connection at the valve  <p style="font-size: small;">Figure 8</p>	Check ground connection at the valve and tighten screw (see figure 8).

Fault Finding Checklist

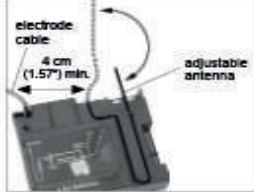
ISSUE	POSSIBLE CAUSE	SOLVE
No transmission: (motor does not turn)	1. Dead batteries	<p>Replace the batteries in the Receiver and/or Remote Handset (quality Alkaline recommended)</p> <p>⚠ WARNING Do not use metal tools to remove batteries. Doing so will render the Receiver inoperable.</p>  <p>Figure 2 Application with internal and external battery box:</p> <p>⚠ WARNING Battery clip (see figure 3) must not come into contact with metal parts after unplugging the external battery holder, because there is voltage stored in the Receiver.</p>  <p>Figure 3</p>
	2. Receiver must learn new code.	<p>Press and hold the Receiver's reset button until you hear 2 acoustic noises signal, release the reset button. Within the subsequent 20 seconds press the flame button. You should hear two additional short beeps confirming the new code is set.</p>
	3. The Receiver is surrounded by metal reducing the transmission range.	<p>Change the position of the adjustable antenna.</p>  <p>Figure 5</p>

ISSUE	POSSIBLE CAUSE	SOLVE
Continued No transmission: (motor does not turn)	4. Receiver	Replace Receiver and reprogram, code (see OBSERVED PROBLEM C, REMEDY to POSSIBLE CAUSE 2)
	5. Transmitter	Replace the Transmitter and reprogram code (SEE OBSERVED PROBLEM C, REMEDY to POSSIBLE CAUSE 2).
	6. Bent pins on 8 Wire Connector on the Valve and Receiver (see figure 6 & 7)	<p>Straighten pins on 8 Wire Connector</p>  <p>Figure 6</p>
	7. Wiring at Valve Damaged	Replace Valve

Fault Finding Checklist

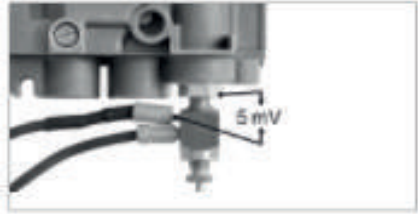
ISSUE	POSSIBLE CAUSE	SOLVE
No pilot flame but spark	1.No gas supply	Check the gas supply.
	2.Air in the pilot supply line	Purge the line or start ignition several times.
	3.No spark at Pilot Burner	Check manufacturer’s instructions for pilot setup; check wiring connection. Check for spark in location along Cable.
	4.Valve	Replace Valve. Do not overtighten the Thermocouple Interrupter.
	5.Receiver	Replace Receiver and reprogram code (see OBSERVED PROBLEM C, REMEDY to POSSIBLE CAUSE 2)
	6.Thermocouple circuit wired incorrectly	Check polarity the Thermocouple Wires.
Pilot is lit and sparking stops. Valve shuts off after 10...60 seconds. Valve does not operate manually. NOTE: For manual operation turn the valve knob to the manual position and hold the safety magnet open with a pen for approximately 60 seconds (see figure 9)	1.Not enough voltage generated from the Thermocouple or too much resistance in the circuit. NOTE: To find which part of the circuit is causing the problem, a checklist for each application can be prepared using an Excel calculation. Possible parts causing excessive resistance are: ON-OFF Switch, Temperature Switches, Thermocurrent Connections, Receiver.	Use a digital multi meter set in the mV range and measure the voltage by connecting the test leads to the spade connector. Spade connector is located on the outer surface directly beside the magnet nut (see figure 10). The available voltage must be at least 5mV. The manufacturer must specify the drop time for the application. The drop time can be measured after the Thermocouple is heated. 
	2.Thermocouple	Replace Thermocouple
	3.Low inlet pressure to Valve	Confirm sufficient inlet pressure to the valve. Adjust or replace inlet regulator if necessary
	4.Valve	Replace Valve. Do not overtighten the Thermocouple Interrupter.

Spare Parts

No. on Diagram	Item	Code
1	Thermocouple	CG30182
2	Gas Valve Assembly Natural	RK0_N1_GV60
2	Gas Valve Assembly LPG	RK10_P1_GV60
3	Pilot Assembly Natural	G30-ZP2-312
3	Pilot Assembly LPG	G30-ZP2-271
4	Pilot Assembly Gasket	G30PSZPS2
5	Flexible Tube 8 x 300mm.s. s	IGO8030
6	Latching Solenoid	GV-S60C/12
	Front Window Panel (Not Shown)	N41045001
	Ceramic Log Pack (Not Shown)	N-Logset
	Electrode (Not Shown)	G30-SPK1
	Electrode Lead (Not Shown)	G60-ZKIS1/1500
	Receiver unit (Not Shown)	G6R-R4AS
	Handset (Not Shown)	G6R-H4D

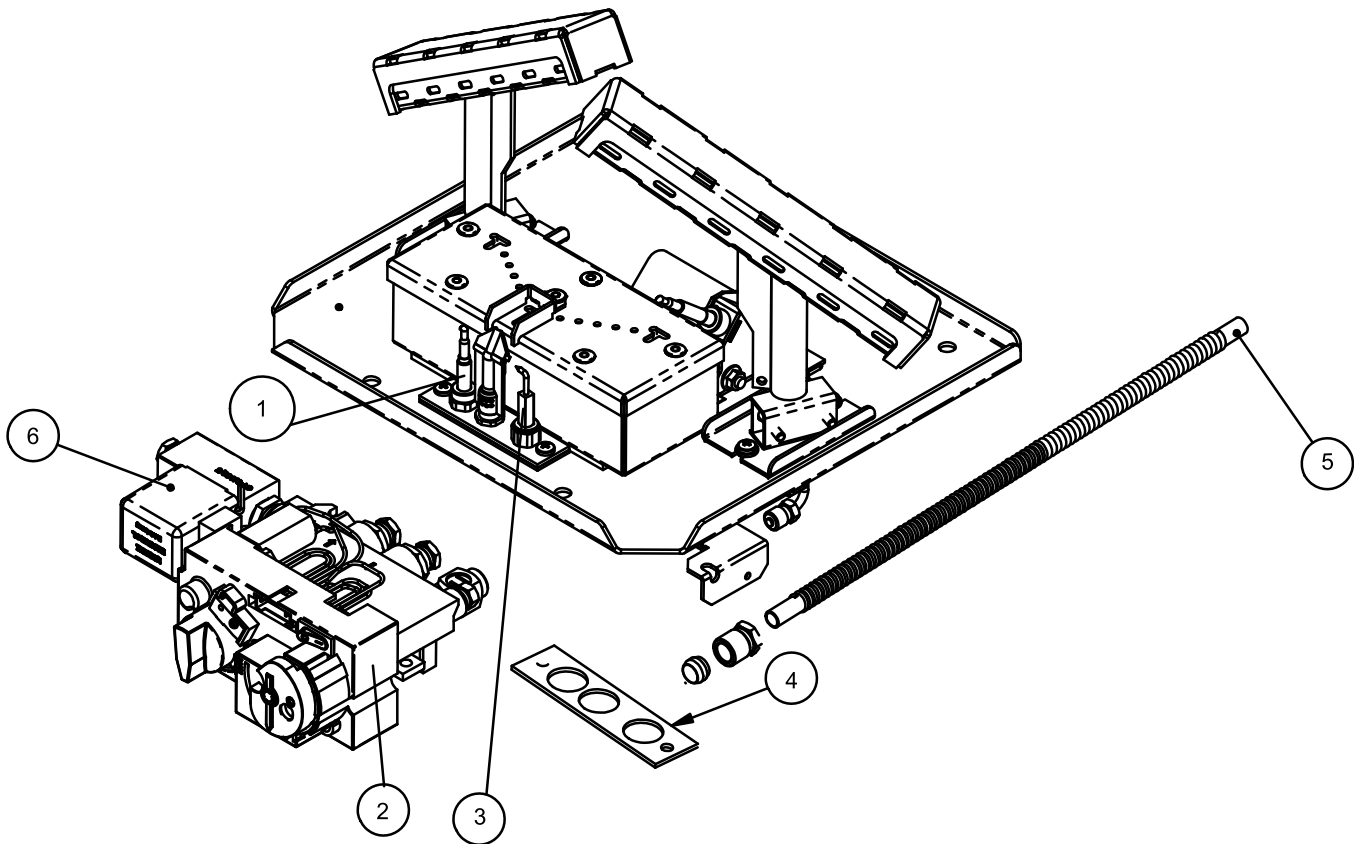

Technical Information

Country	Natural	LPG
AT -Austria	I _{2H} , G20 at 20 mbar	I _{3P(50)} ,G31 at 50 mbar; I _{3B/P(50)} ,G30/G31 at 50 mbar
BE -Belgium	I _{2E+} , G20/G25 at 20/25 mbar	I ₃₊ ,G31/G31 at 28/37 mbar; I _{3P(37)} ,G31 at 37 mbar; I _{3B/P(30)} ,G30/G31 at 30 mbar
BG -Bulgaria	I _{2H} , G20 at 20 mbar	I _{3B/P(30)} ,G30/G31 at 30 mbar
CH - Switzerland	I _{2H} , G20 at 20 mbar	I _{3P(50)} ,G31 at 50 mbar; I ₃₊ ,G31/G31 at 28/37 mbar; I _{3P(37)} ,G31 at 37 mbar; I _{3B/P(50)} ,G30/G31 at 50
CY -Cyprus	I _{2H} , G20 at 20 mbar	I ₃₊ ,G31/G31 at 28/37 mbar; I _{3B/P(30)} ,G30/G31 at 30 mbar
CZ -Czech Republic	I _{2H} , G20 at 20 mbar	I _{3P(50)} ,G31 at 50 mbar; I ₃₊ ,G31/G31 at 28/37 mbar; I _{3P(37)} ,G31 at 37 mbar; I _{3B/P(50)} ,G30/G31 at 50
DE -Germany	I _{2ELL} , G25 at 20 mbar ¹ ; I _{2E} , G20 at 20 mbar	I _{3P(50)} ,G31 at 50 mbar; I _{3B/P(50)} ,G30/G31 at 50
DK -Denmark	I _{2H} , G20 at 20 mbar	I _{3B/P(30)} ,G30/G31 at 30 mbar
EE -Estonia	I _{2H} , G20 at 20 mbar	I _{3B/P(30)} ,G30/G31 at 30 mbar
ES -Spain	I _{2H} , G20 at 20 mbar	I ₃₊ ,G31/G31 at 28/37 mbar; I _{3P(37)} ,G31 at 37 mbar
FI -Finland	I _{2H} , G20 at 20 mbar	I _{3P(30)} ,G31 at 30 mbar; I _{3B/P(30)} ,G30/G31 at 30 mbar
FR -France	I _{2E+} , G20/G25 at 20/25 mbar	I ₃₊ ,G31/G31 at 28/37 mbar; I _{3P(37)} ,G31 at 37 mbar; I _{3B/P(30)} ,G30/G31 at 30 mbar; I _{3B/P(50)} ,G30/G31 at 50
GB -United Kingdom	I _{2H} , G20 at 20 mbar	I ₃₊ ,G31/G31 at 28/37 mbar; I _{3P(37)} ,G31 at 37 mbar; I _{3B/P(30)} ,G30/G31 at 30 mbar
GR -Greece	I _{2H} , G20 at 20 mbar	I ₃₊ ,G31/G31 at 28/37 mbar; I _{3P(37)} ,G31 at 37 mbar; I _{3B/P(30)} ,G30/G31 at 30 mbar
HU -Hungary		I _{3B/P(30)} ,G30/G31 at 30 mbar
HR -Croatia	I _{2H} , G20 at 20 mbar	I _{3P(37)} ,G31 at 37 mbar; I _{3B/P(30)} ,G30/G31 at 30 mbar
IE -Ireland	I _{2H} , G20 at 20 mbar	I ₃₊ ,G31/G31 at 28/37 mbar; I _{3P(37)} ,G31 at 37 mbar
IS -Iceland		
IT -Italy	I _{2H} , G20 at 20 mbar	I ₃₊ ,G31/G31 at 28/37 mbar; I _{3P(37)} ,G31 at 37 mbar; I _{3B/P(30)} ,G30/G31 at 30 mbar
LT -Lithuania	I _{2H} , G20 at 20 mbar	I ₃₊ ,G31/G31 at 28/37 mbar; I _{3P(37)} ,G31 at 37 mbar; I _{3B/P(30)} ,G30/G31 at 30 mbar
LU -Luxembourg	I _{2E} , G20 at 20 mbar	
LV -Latvia	I _{2H} , G20 at 20 mbar	
MT -Malta		I _{3B/P(30)} ,G30/G31 at 30 mbar
NL -The Netherlands	I _{2L} , G25 at 25 mbar I _{2EK} , G25.3 at 25 mbar I _{2(43.46 -45.3 MJ/m3 (0°C))} , G25.3 at 25 mbar	I _{3P(50)} ,G31 at 50 mbar; I _{3P(30)} ,G31 at 30 mbar; I _{3P(37)} ,G31 at 37 mbar; I _{3B/P(30)} ,G30/G31 at 30 mbar
NO -Norway	I _{2H} , G20 at 20 mbar	I _{3B/P(30)} ,G30/G31 at 30 mbar
PL -Poland	I _{2E} , G20 at 20 mbar	I _{3P(37)} ,G31 at 37 mbar
PT -Portugal	I _{2H} , G20 at 20 mbar	I ₃₊ ,G31/G31 at 28/37 mbar; I _{3P(37)} ,G31 at 37 mbar
RO -Romania	I _{2E} , G20 at 20 mbar	I _{3P(30)} ,G31 at 30 mbar; I _{3B/P(30)} ,G30/G31 at 30 mbar
SE - Sweden	I _{2H} , G20 at 20 mbar	I _{3B/P(30)} ,G30/G31 at 30 mbar
SL -Slovenia	I _{2H} , G20 at 20 mbar	I ₃₊ ,G31/G31 at 28/37 mbar; I _{3P(37)} ,G31 at 37 mbar; I _{3B/P(30)} ,G30/G31 at 30 mbar
SK -Slovakia	I _{2H} , G20 at 20 mbar	I _{3P(50)} ,G31 at 50 mbar; I ₃₊ ,G31/G31 at 28/37 mbar; I _{3P(37)} ,G31 at 37 mbar; I _{3B/P(30)} ,G30/G31 at 30 mbar; I _{3B/P(50)} ,G30/G31 at 50
TR -Turkey	I _{2H} , G20 at 20 mbar	I ₃₊ ,G31/G31 at 28/37 mbar; I _{3P(37)} ,G31 at 37 mbar; I _{3B/P(30)} ,G30/G31 at 30 mbar

Technical Data

Gas type		G20 I2H,I2E	G20/G25 I2E+	G25/G25.3 I2L/ I2EK I2(43.46 -45.3 MJ/m3 (0°C))	G20/G25 I2ELL
Supply Pressure	mbar	20	20 / 25	25	20
Nominal Heat Input Gross (Hs)	kW	9.1	9.1 / 8.4	8.5	7.5
Nominal Heat Input Nett (Hi)	kW	8.2	8.2 / 7.6	7.7	6.8
Consumption	m ³ /hr	0.84	0.840 / 0.905	0.89	0.8
Burner Pressure (hot)	mbar	13.2	13.2 / 16.4	16.6	13.4
Injector Marking	120 Centre, 260 Left, 260 Right				
Pilot	G30-ZP2-312 (31.2 inj)				
Efficiency Class	1				
Nox Class	5				
Type	C11 / C31				

Gas type		G30/G31 I3B/P(30)	G30/G31 I3+	G31 I3P(50)	G31 I3P(37)	G31 I3P(30)
Supply Pressure	mbar	30	30 / 37	50	37	30
Nominal Heat Input Gross (Hs)	kW	8	8	8	8	7
Nominal Heat Input Nett (Hi)	kW	7.4	7.4	7.4	7.4	6.5
Consumption	m ³ /hr	0.225	0.225 / 0.29	0.29	0.29	0.253
Burner Pressure (hot)	mbar	27	27 / 36	36	36	28
Injector Marking	80 Centre, 100 Left, 100 Right					
Pilot	G30-ZP2-271 (27.1 inj)					
Efficiency Class	1					
Nox Class	5					
Type	C11 / C31					

This product has been tested and certified for use on Biopropane Gas.
Biopropane Gas can be used as a fuel, with no adjustment necessary if the product is installed as an LPG version.

Dimensions

NEO3FGAS

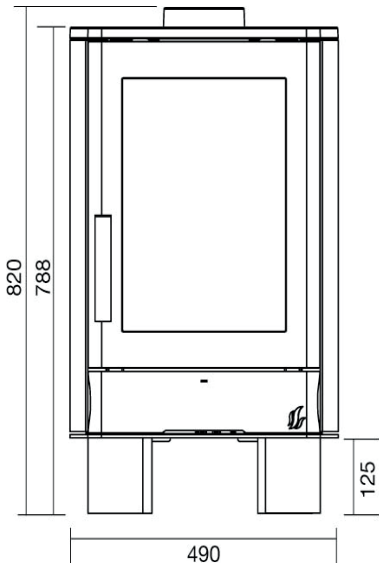

NEO3WGAS

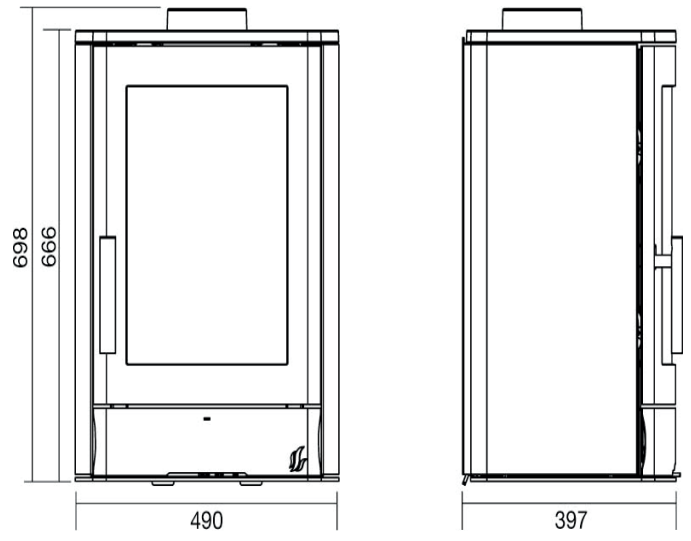

NEO3CGAS

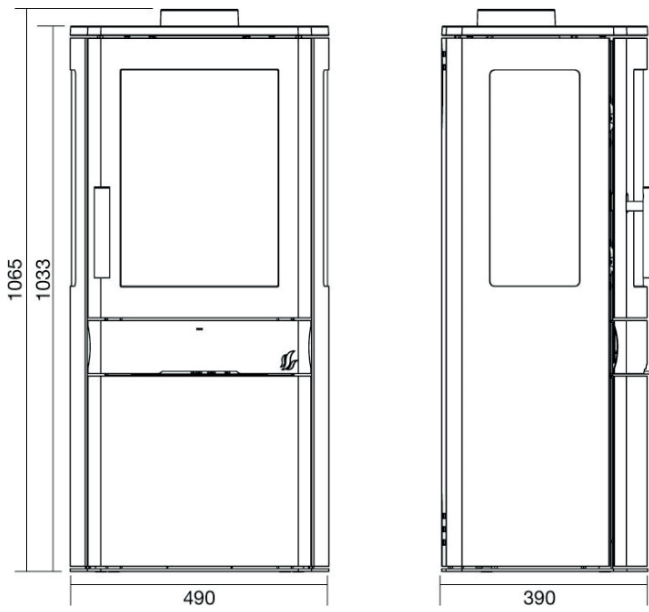

NEO3PGAS

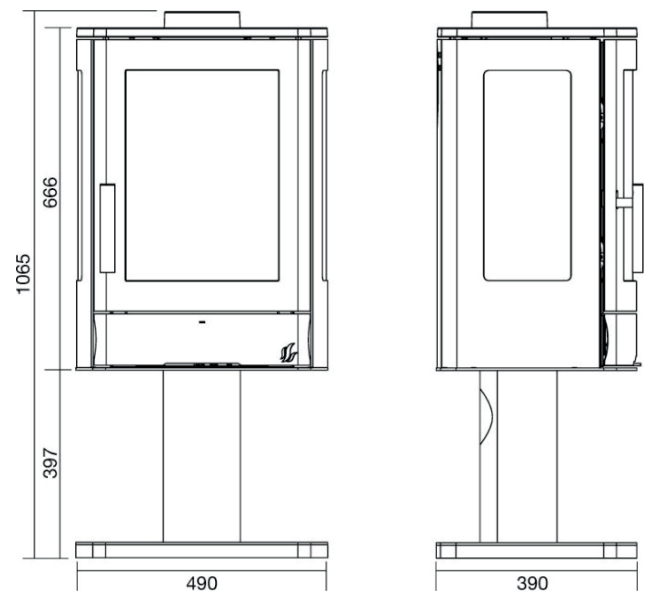

Servicing

Turn the appliance OFF and isolate the gas supply. Ensure the appliance is fully cold before attempting to start servicing the appliance. No liability can be accepted by ACR for injury caused by burning or scolding by a hot appliance.

A suggested procedure for servicing is listed below

- A. Lay out dust sheet on flooring, mask off any special fireplace materials.
- B. Remove the door lock.
- C. Open the front door assembly.
- D. Carefully remove the ceramic components (including embers).
- E. Use a vacuum cleaner to clean the top of the burners and aeriated base
- F. Remove perforated grate
- G. Using a vacuum cleaner, fully clean the burner.
- H. Use the vacuum cleaner and a soft brush to clean the pilot assembly and injectors. Never modify or bend the thermocouple
- I. Turn on the gas supply and check for leaks, check the burners and pilot for good condition and operation
- J. Replace perforated grate.
- K. Replace the fire bed arrangements
- L. Check door rope seals
- M. Close front door & lock using the grub screws
- N. Check the flue system and terminal, making sure that their terminal vent is fully clear
- O. Light the appliance and test setting pressures
- P. Check the safe operation of the appliance

Cleaning the Ceramics

Remove the ceramics as detailed in A - D above.

Gently clean the ceramics in the open air, using a soft brush and a vacuum cleaner. Where necessary replace damaged components only with genuine ACR specified parts. Seal any scrap ceramics in plastic bags and dispose at proper refuse sites. When using a vacuum cleaner, it is recommended that one with a HEPA filtering system is used.

Re-fit the fire bed arrangement, re-seal the appliance and check the safe operation of the appliance.

Servicing the Burners

Remove the ceramics as detailed in A - D above.

The pilot is now clearly visible, the pilot, including the thermocouple, can be replaced/serviced by removing raising the pilot assembly from its mounting. This is done by removing the two screws on the surface of the pilot. The fittings on the under-side of the pilot can be un-done using a 10mm spanner where appropriate.

To access the main burner injectors, the burner base units must be removed. This is done by removing the four bolts (M6, 10mm spanner) holding the burner in. With these four bolts removed, the burner base can be raised up through the firebox, and the injectors can be easily accessed.

When replacing any parts use only original ACR specified parts.

Annual Service Record

Annual Service Record Year 1	Annual Service Record Year 2
Gas Safe Registered Engineer:	Gas Safe Registered Engineer:
Contact No:	Contact No:
Gas Safe Register No:	Gas Safe Register No:
Date of Service:	Date of Service:
Door Seal replaced:	Door Seal replaced:

Annual Service Record Year 3	Annual Service Record Year 4
Gas Safe Registered Engineer:	Gas Safe Registered Engineer:
Contact No:	Contact No:
Gas Safe Register No:	Gas Safe Register No:
Date of Service:	Date of Service:
Door Seal replaced:	Door Seal replaced:

Annual Service Record

Annual Service Record Year 5	Annual Service Record Year 6
Gas Safe Registered Engineer:	Gas Safe Registered Engineer:
Contact No:	Contact No:
Gas Safe Register No:	Gas Safe Register No:
Date of Service:	Date of Service:
Door Seal replaced:	Door Seal replaced:

Annual Service Record Year 7	Annual Service Record Year 8
Gas Safe Registered Engineer:	Gas Safe Registered Engineer:
Contact No:	Contact No:
Gas Safe Register No:	Gas Safe Register No:
Date of Service:	Date of Service:
Door Seal replaced:	Door Seal replaced:

Warranty – 3 Year Warranty

With the aim of constantly improving our products, all modifications considered necessary may be made without notice.

This manual is correct at time of printing.

Our appliances are guaranteed against faults and hidden defects subject to the following conditions:

- The appliance must have been installed by a registered competent Gas Safe installer.
- The appliance must be installed and operated in accordance with our instruction manual.
- The appliance must be serviced annually by a Gas Safe Engineer & recorded in the manual.
- All Stoves are covered by a 3 year warranty which covers the burner and all stove body castings / stove body steel panels. It does not include consumable items such as glass, door seals, vermiculite panels, baffle plates, grates, thermocouples, oxypilots, fuel effects, batteries, paint finish & internal linings.
- This 3 year warranty is only applicable when the stove is purchased from one of our recommended retailers. If a stove from any of our brands is purchased from a non-recommended retailer then only a 12 month warranty will be applicable as outlined below.
- All stoves are covered by a 1 year warranty when purchased through a non-recommended retailer. The warranty covers the stove body castings only and does not include consumable items such as glass, door seals, vermiculite panels, baffle plates, grates, thermocouples, oxypilots, fuel effects, batteries, paint finish & internal linings.
- The warranty does not cover damage caused by unauthorised modifications, use or repair
- The warranty does not include removal or reinstallation costs, or consequential losses related to associated products not supplied by ACR.
- The warranty does not cover damage caused through incorrect storage of product eg. damp or unheated areas.
- The warranty does not cover faults, damage or defects caused by environmental conditions such as salt air, flue defects & draught problems.
- Your statutory rights are not affected by this warranty.
- Any replacement parts fitted to the appliance must be genuine ACR parts. The fitting of non – genuine parts will invalidate the warranty.
- The specifications within this document are provided for information purposes only and are under no circumstances binding.
- Full warranty information can be viewed on our website www.acrheatproducts.com/warranties

Warranty Claim Form

In the unlikely event of a warranty claim, please complete the below claim form and return it to your supplying dealer:

Customer Name:

Customer Address:

Postcode:

Daytime Tel:

Mobile Tel:

Model Name:

Model Number:

Serial Number:

Date of purchase:

Date of installation:

Installer's Name and address:

Installer's Registration Number:

Dealer Name and address:



ACR Heat Products

Unit 1 Weston Works, Weston Lane,

Birmingham, West Midlands,

UK, B11 3RP

Tel: 0121 706 8266

Website: www.acrheatproducts.com

Email: enquiries@acrheatproducts.co.uk